

# Minimum RC™

## P-51 Mustang Assembly Instructions



### Important Instructions

- 1.The model is supplied with UFO and 502 glue. UFO is for bonding foam parts, and 502 for bonding wood, carbon fiber and metal parts. 502 glue will cause serious corrosion to foam parts.
- 2.Please wait for the glue to dry and solidify in each installation step before the next installation.
- 3.Please avoid using flame to heat the heat shrinkable tube on the model. Electric iron shall be used for heating.
- 4.Please use razor blade to remove the parts from the plate. Do not tear the parts by force.

1. Fuselage wooden frame parts.

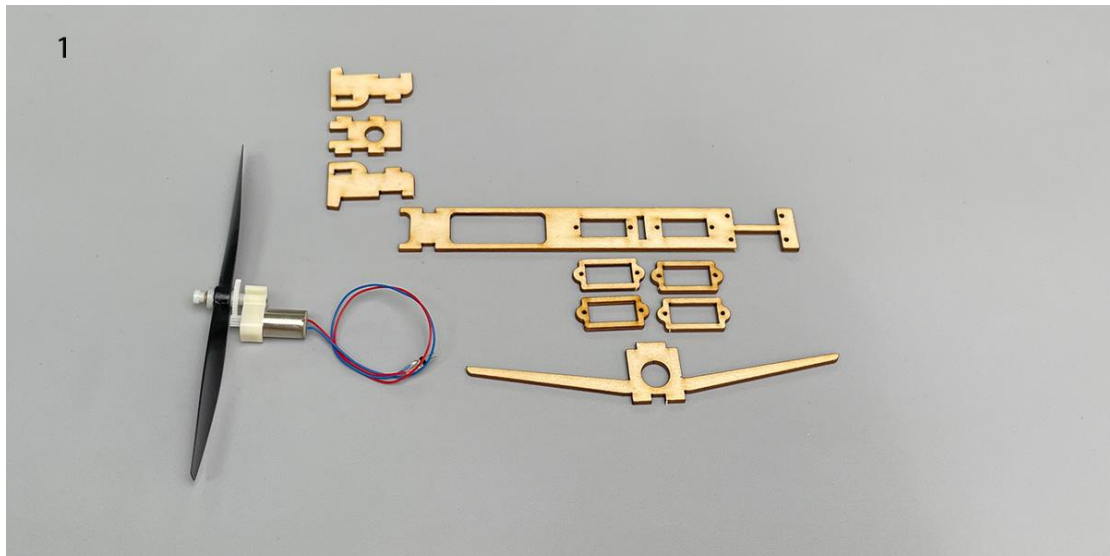

2. Assemble the fuselage wooden frame.

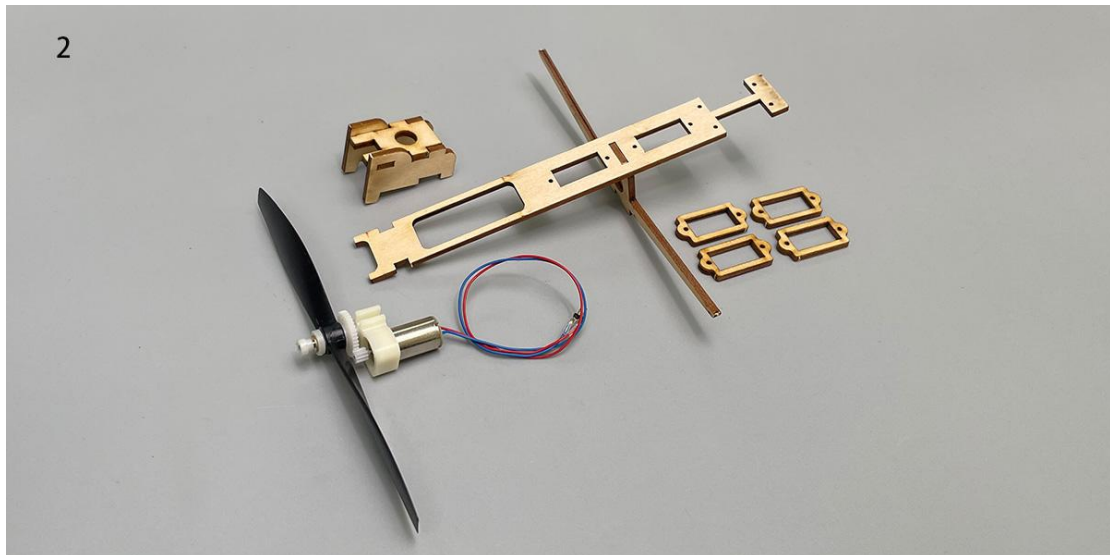

3. Continue assembling the wooden frame and install the motor.

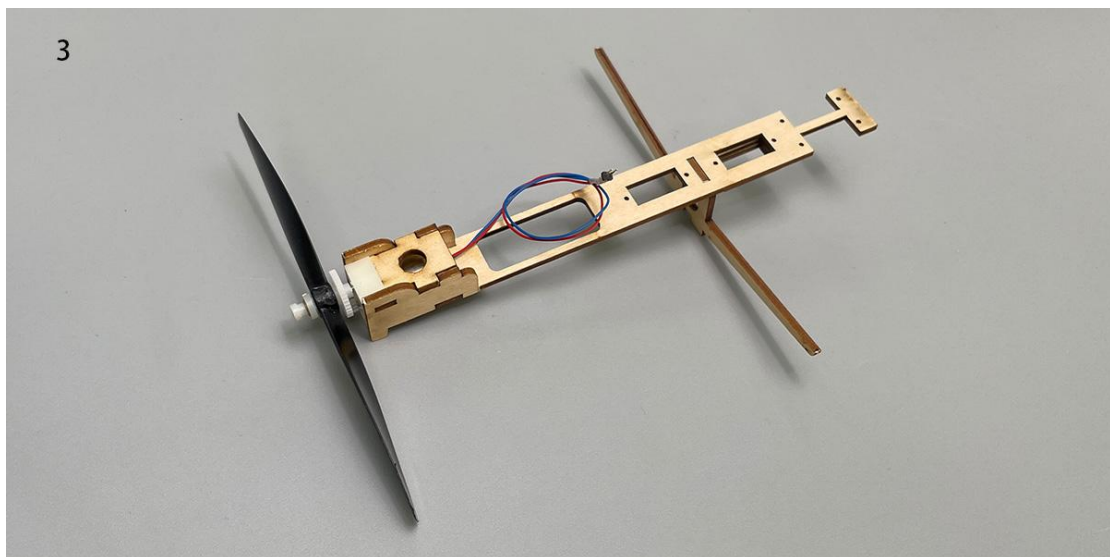

4. Overlap and install two servo wooden spacers. (Bottom view of the parts)

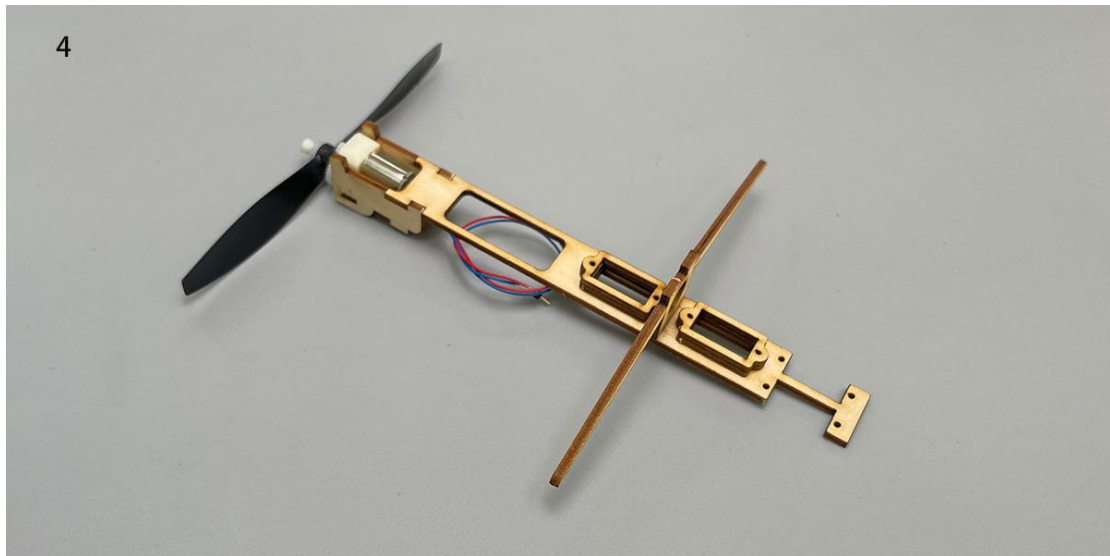

5. Install the servo as shown. (Top view of the parts)

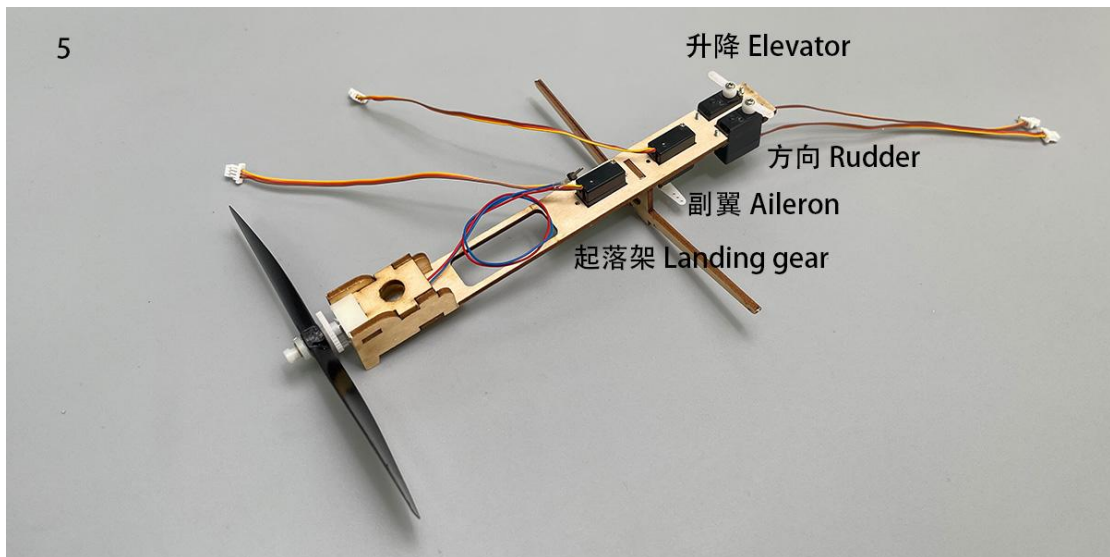

6.

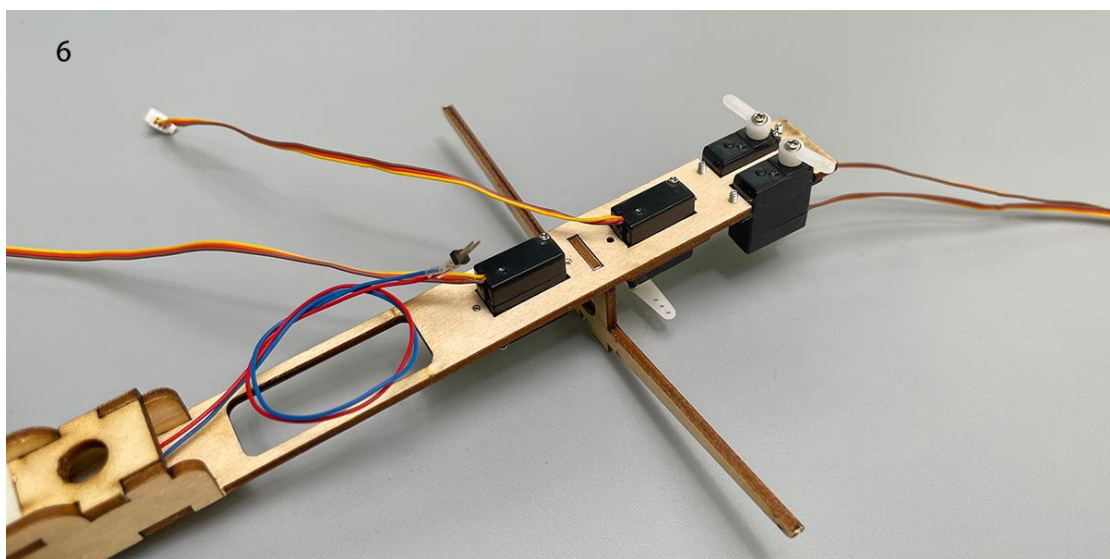

7. Install the servo as shown. (Bottom view of the parts)

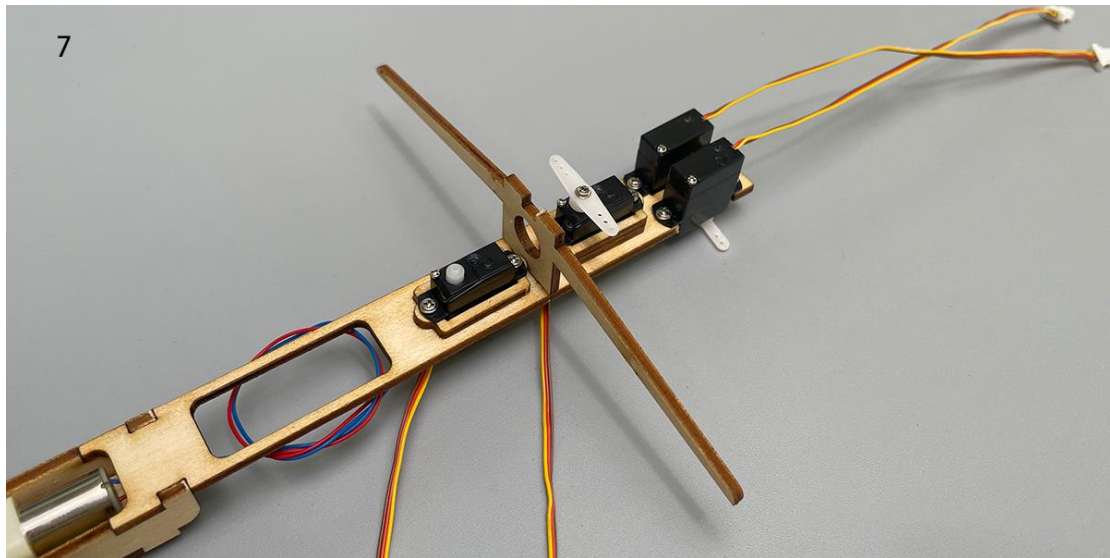

8. The landing gear servo uses a cross-shaped arm.



9. Remove the two opposite arms of the cross-shaped arm (as shown in the diagram).



10. Install the arm onto the landing gear servo.

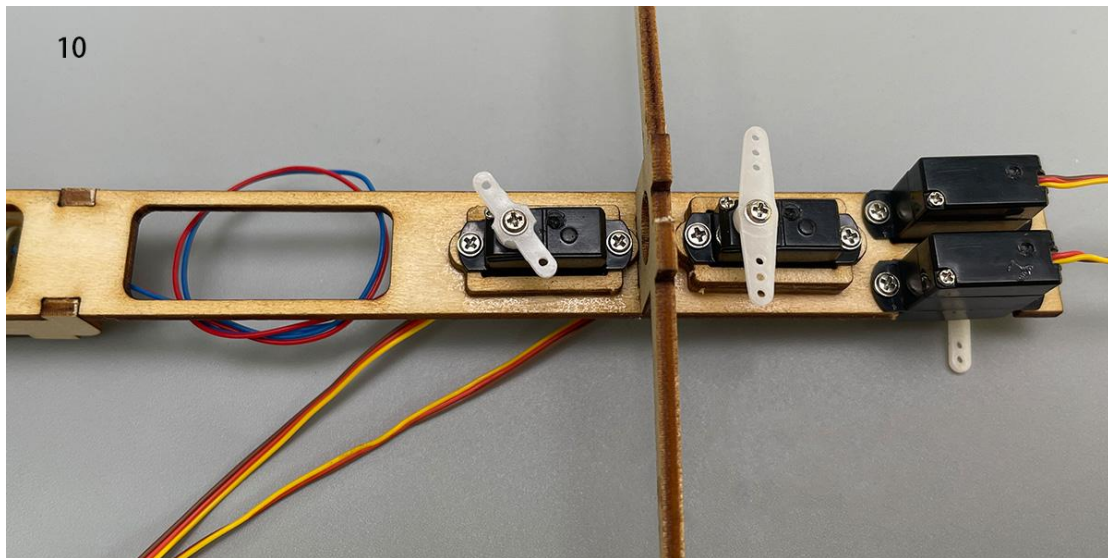

11. Connect the receiver to the servos, secure the receiver with Velcro, power it on, and bind it to the transmitter to ensure that the servo arms return to their neutral positions. Test if the servos are functioning correctly and install the servos and arms as shown in the diagram. Note: This step is crucial; make sure the servos are powered, the arms are centered, and follow the diagram precisely. Adjustments cannot be made after the model is assembled.

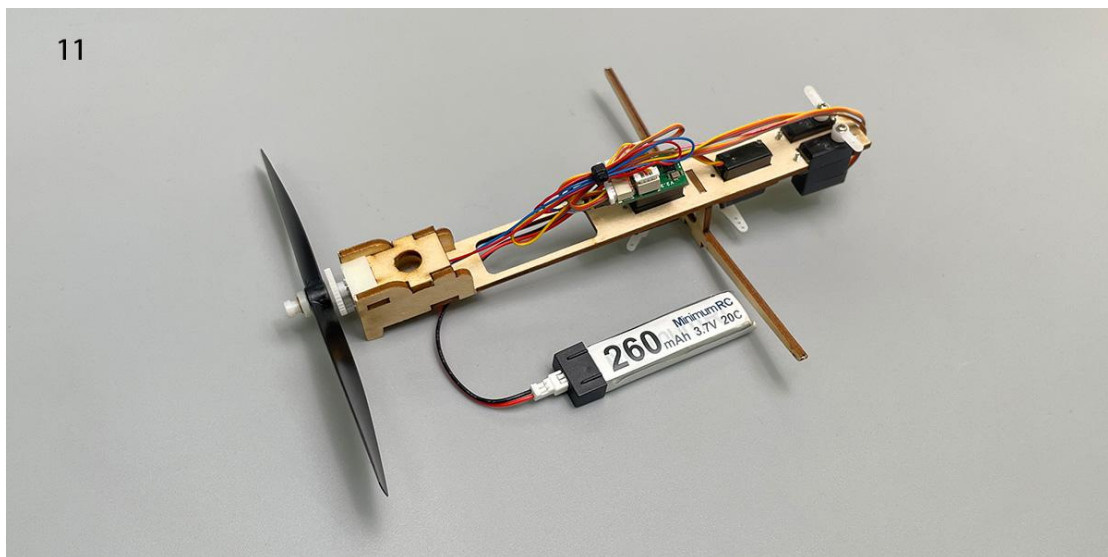

12. Magnets and its supporting structures.

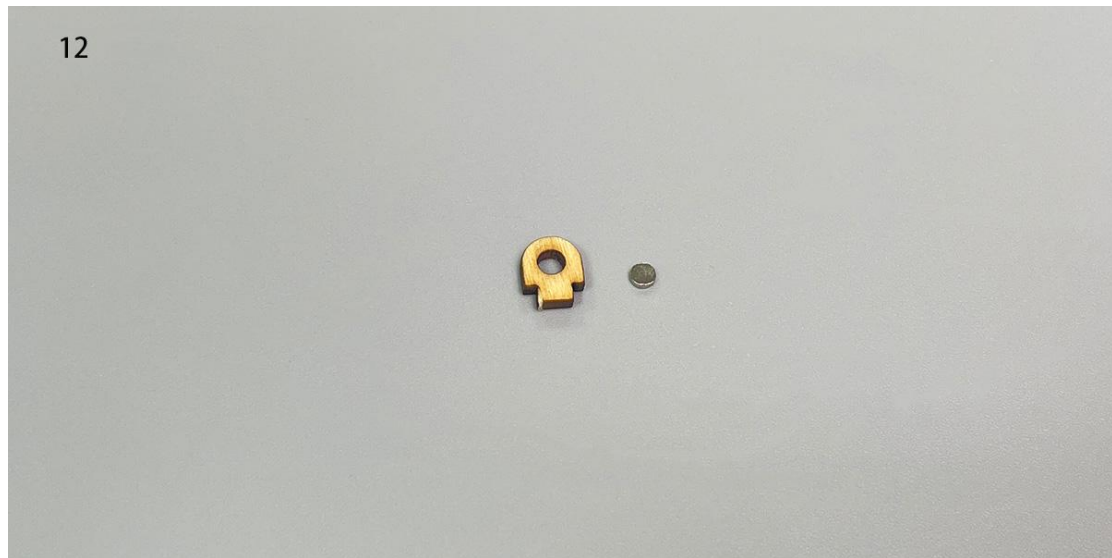

13. Install the magnet.

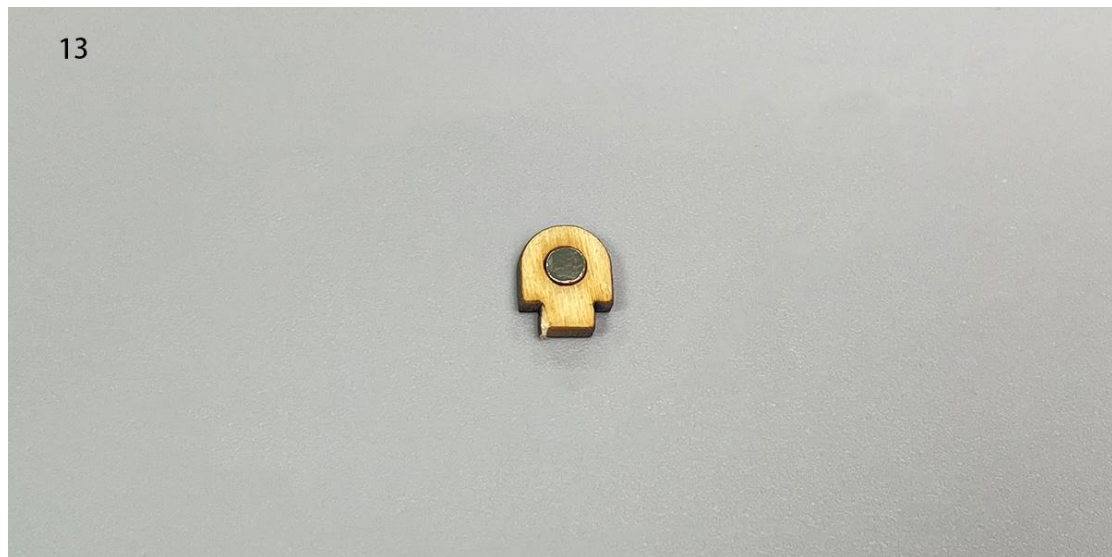

14. Install the assembled magnet-supporting structure onto the wooden frame at the corresponding location.

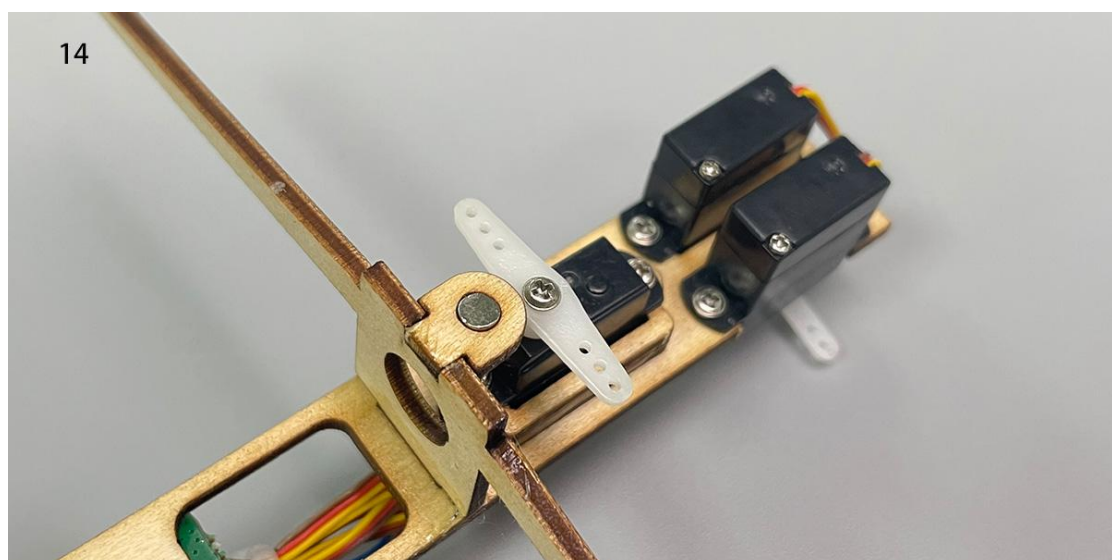

15. airframe components.



16. Use a sharp tool (screwdriver) to score through the marked lines on the bottom of the fuselage.



17. Use glue to secure the wooden frame and attach the fuselage to one sides of the wooden frame, with the side marked with lines facing inward.



18. PS foam parts.

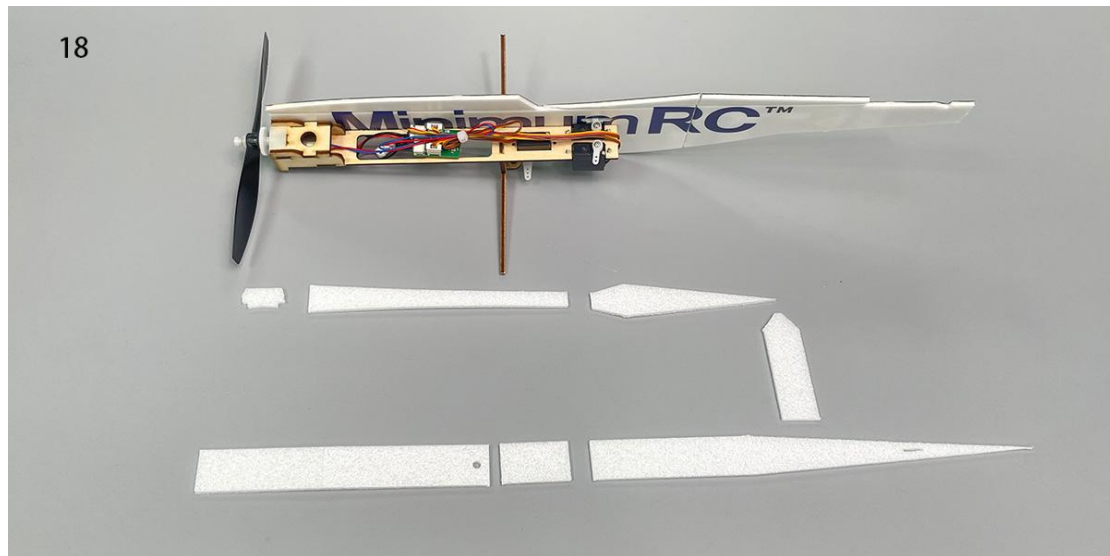

19. Press the fuselage inward along the score lines and use glue to install the bulkhead.



20. Use glue to secure the cockpit foam board.

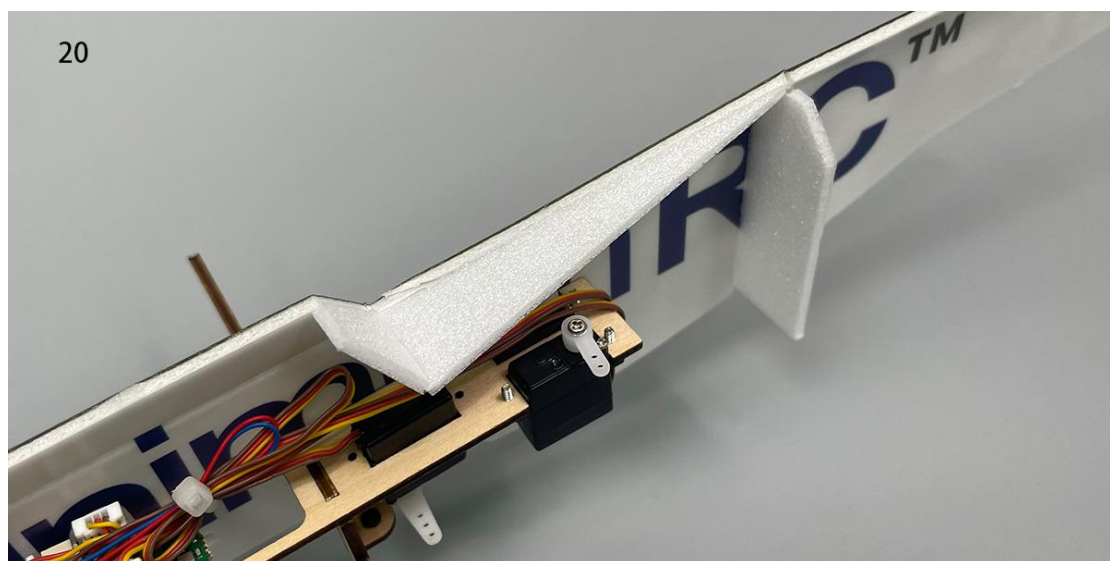



21. Use glue to secure the front fuselage top plate and nose filler plate.

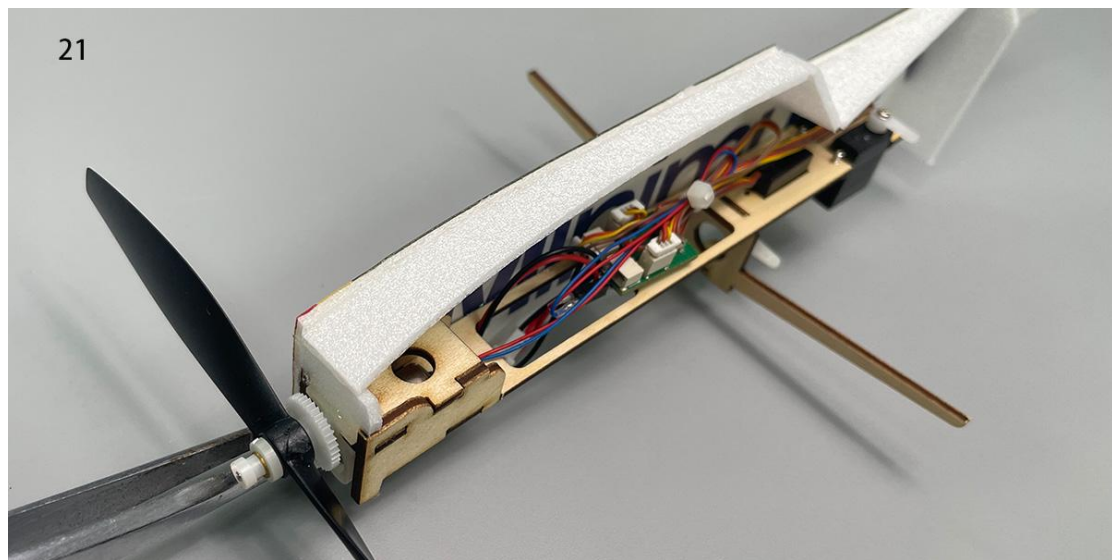

22. Use glue to secure the fuselage bottom plate, do not apply glue to the red-lined section.

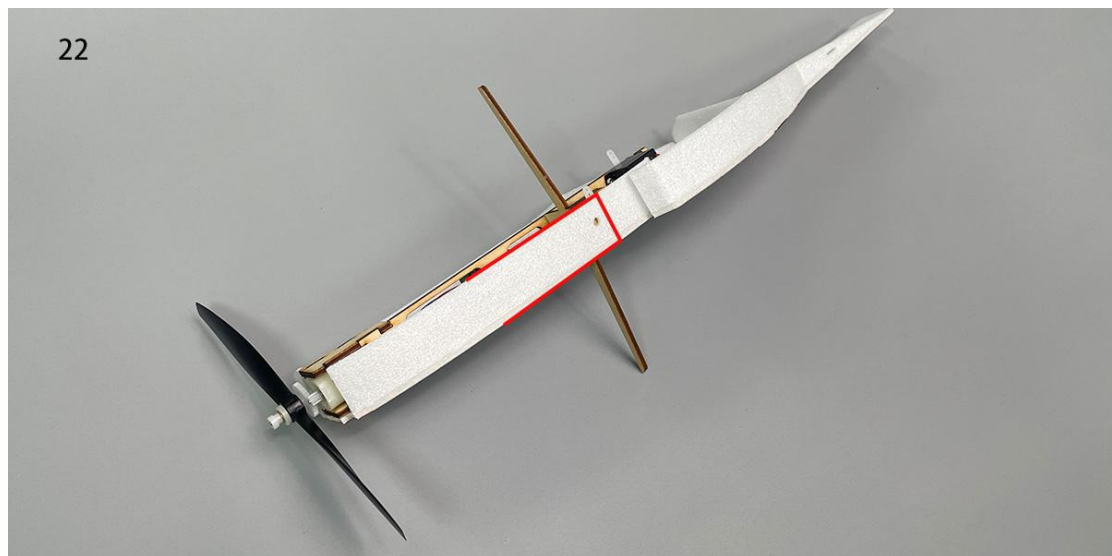

23.

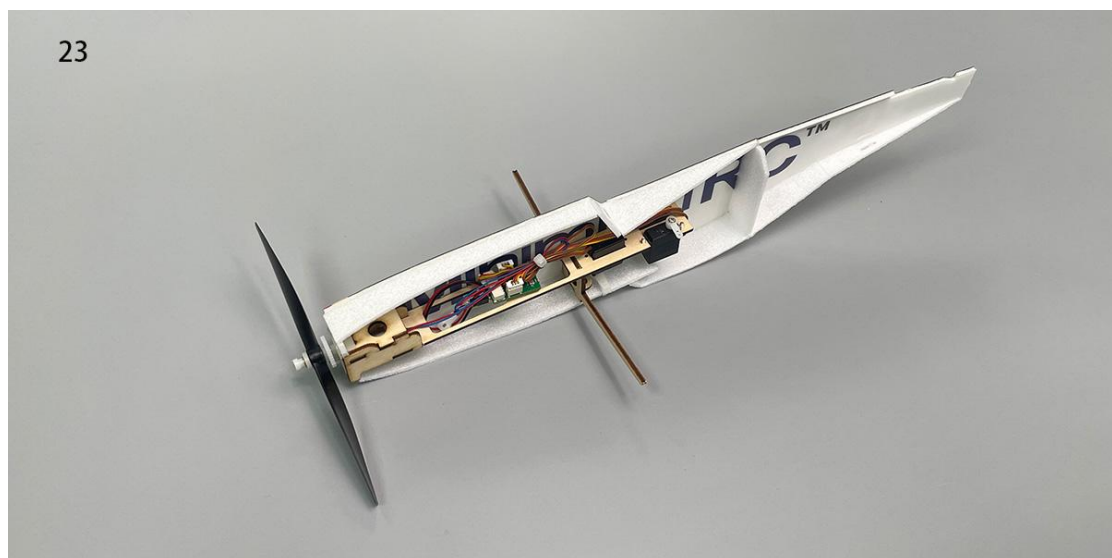

24. Combine the fuselage.



25. Remove the propeller and apply the fuselage stickers.



26. The front bottom plate of the fuselage can be opened forward as a battery compartment cover.

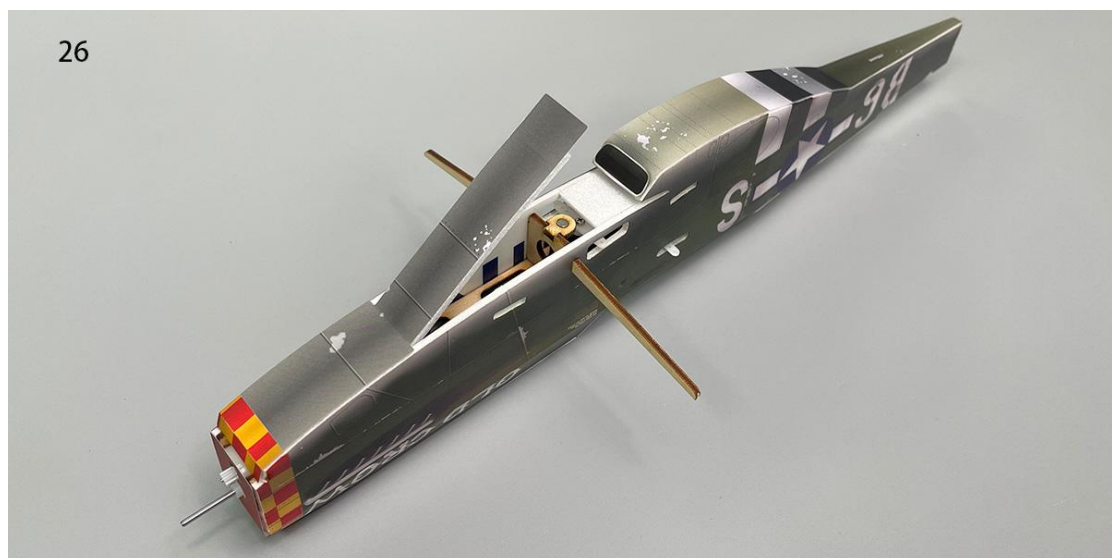

27. Install magnets at the circular hole position of the battery compartment cover.

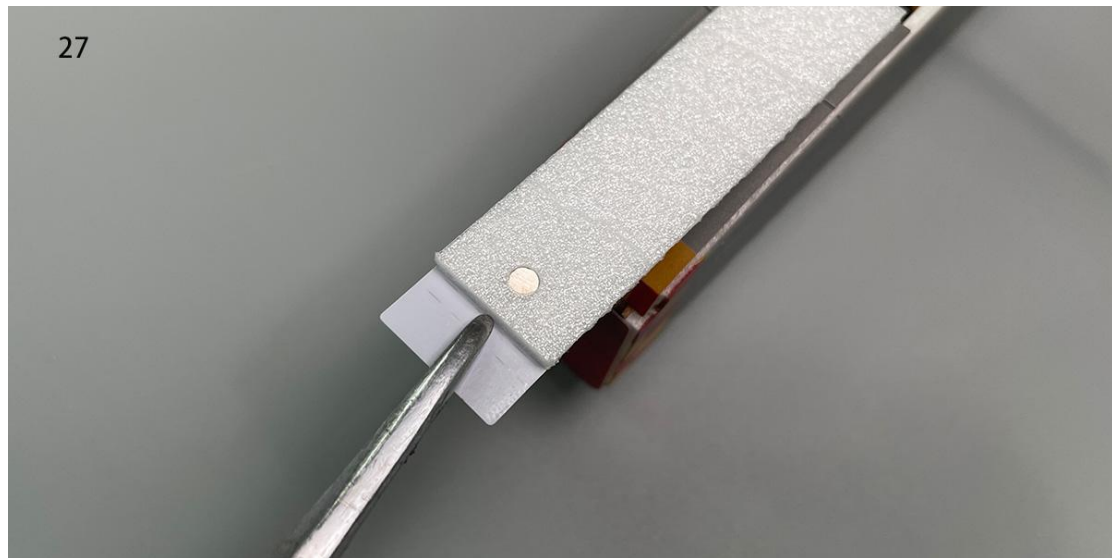

28. Seal the mounting holes with sticker.



29. Install the tailwheel in the corresponding slot on the bottom of the aircraft.

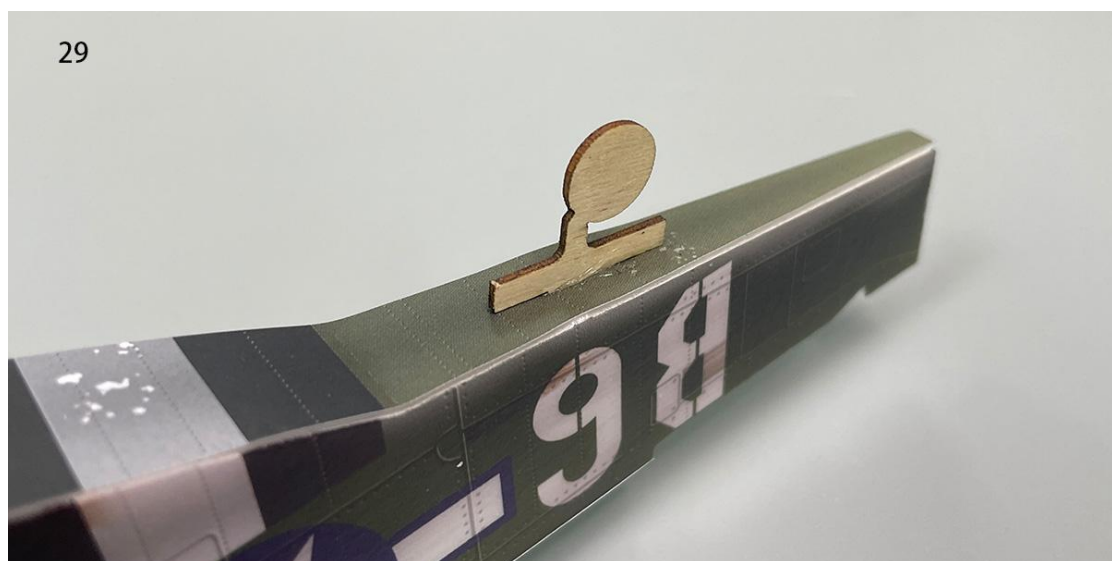

30. Apply stickers to the aircraft tailwheel.

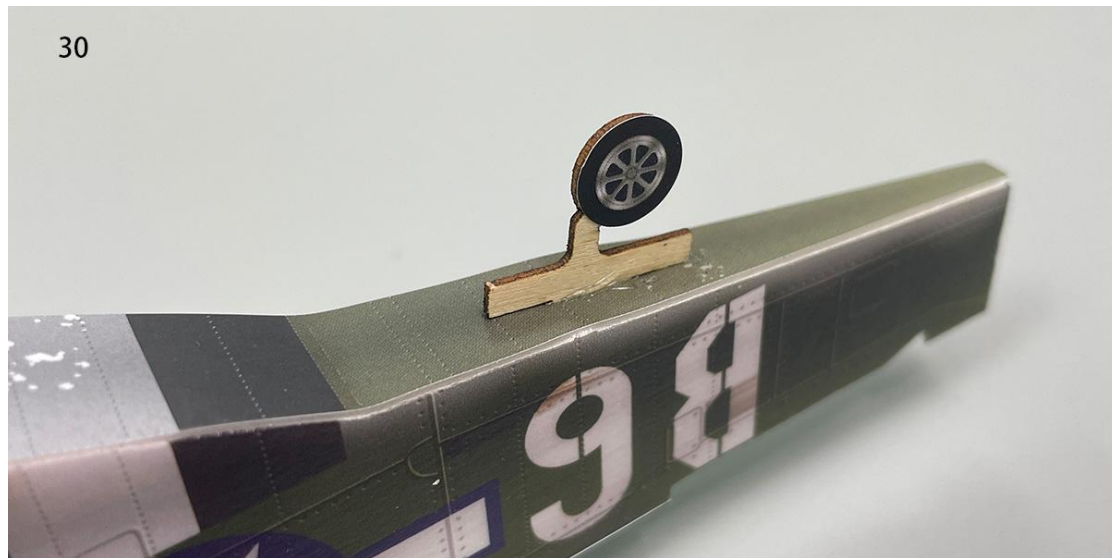

31. Trim the excess portions of the vacuum-formed cabin cover parts as shown in the diagram. It is advisable to make a conservative initial cut, place the cabin cover on the fuselage for alignment, and then proceed with precise adjustments.

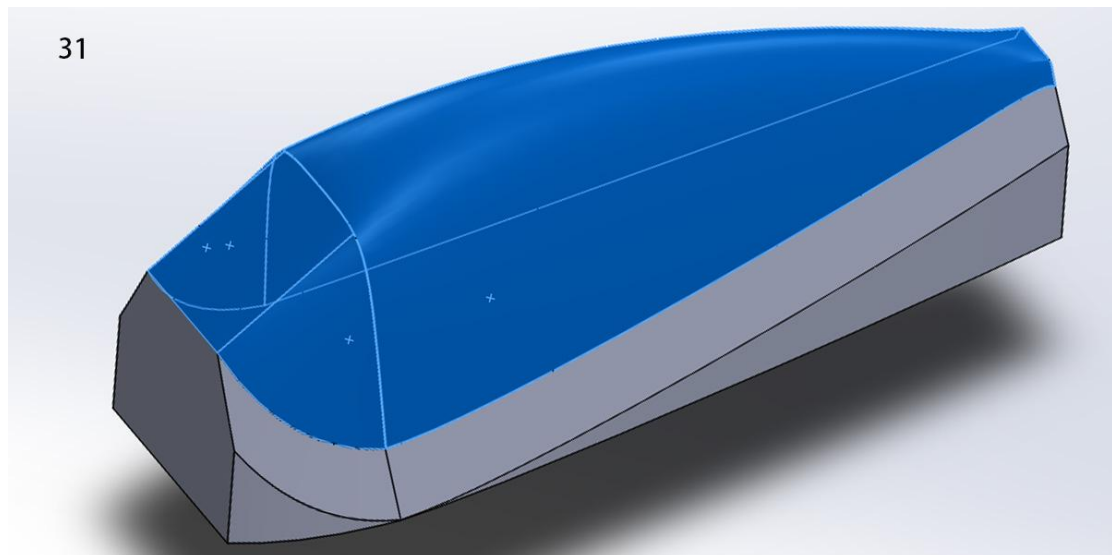

32. Trim to the finished size.

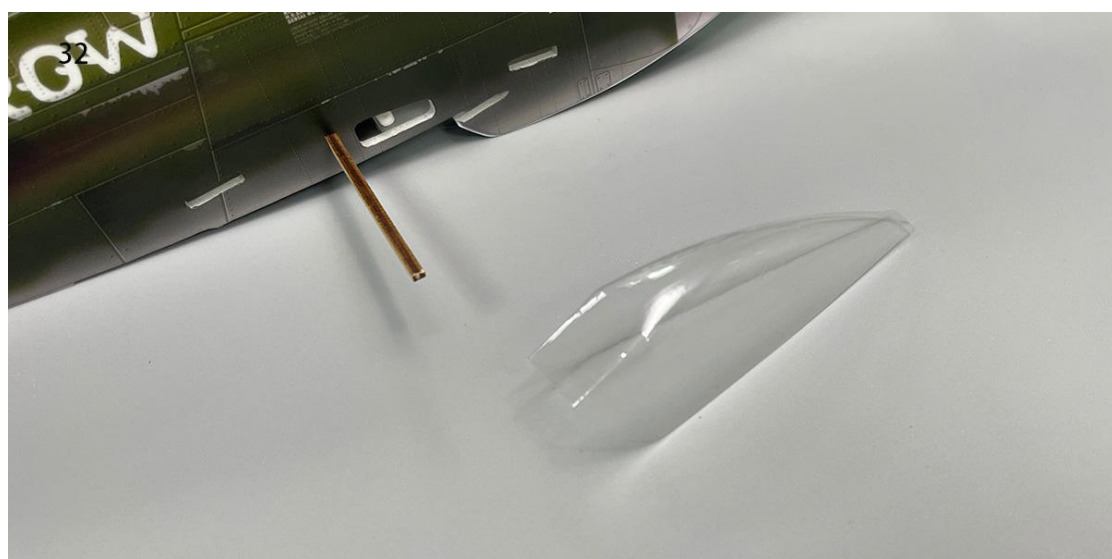

33. Install the canopy onto the fuselage at the corresponding location.



34. Apply stickers to the canopy.



35. Install the propeller and spinner, using a small amount of glue to secure the spinner.



36. Use a sharp tool (screwdriver) to score through the marked lines on the bottom of the horizontal stabilizer, allowing the elevator to move freely along the lines on both sides.

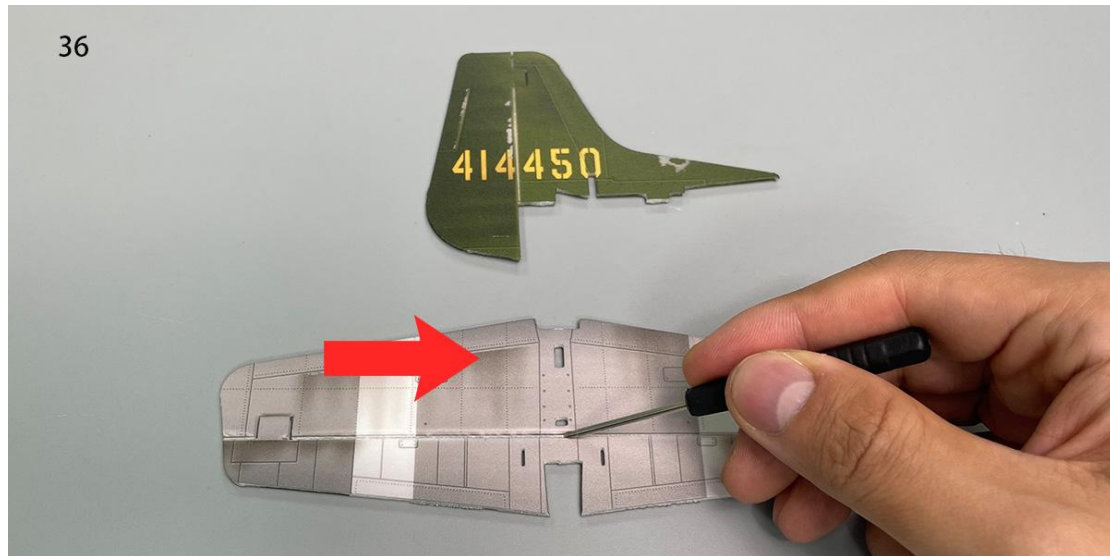

37. Use a sharp tool (screwdriver) to score through the marked lines on the bottom of the vertical stabilizer, allowing the rudder to move freely along the lines on both sides.



38. Install the vertical stabilizer reinforcement.



39. Attach the vertical stabilizer to the horizontal stabilizer.



40. Attach the horizontal stabilizer to the corresponding location on the fuselage, ensuring that the horizontal stabilizer is parallel to the wing spar.



41. Use stickers to conceal the vertical stabilizer reinforcement.



42.

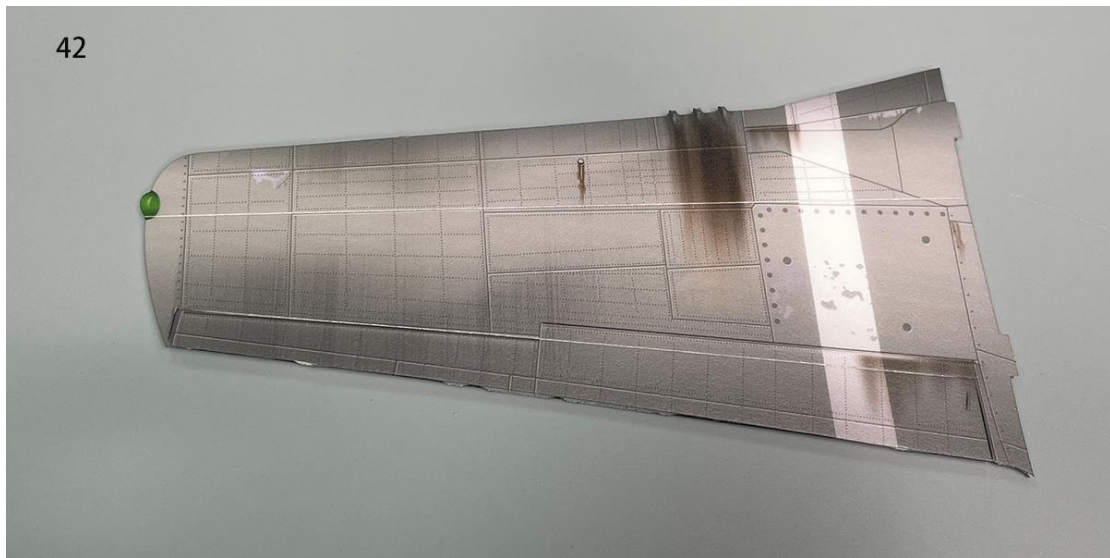

43. Use a sharp tool (screwdriver) to score along the wing's marked line, allowing the wing to fold downward along the center longitudinal line to form the airfoil.

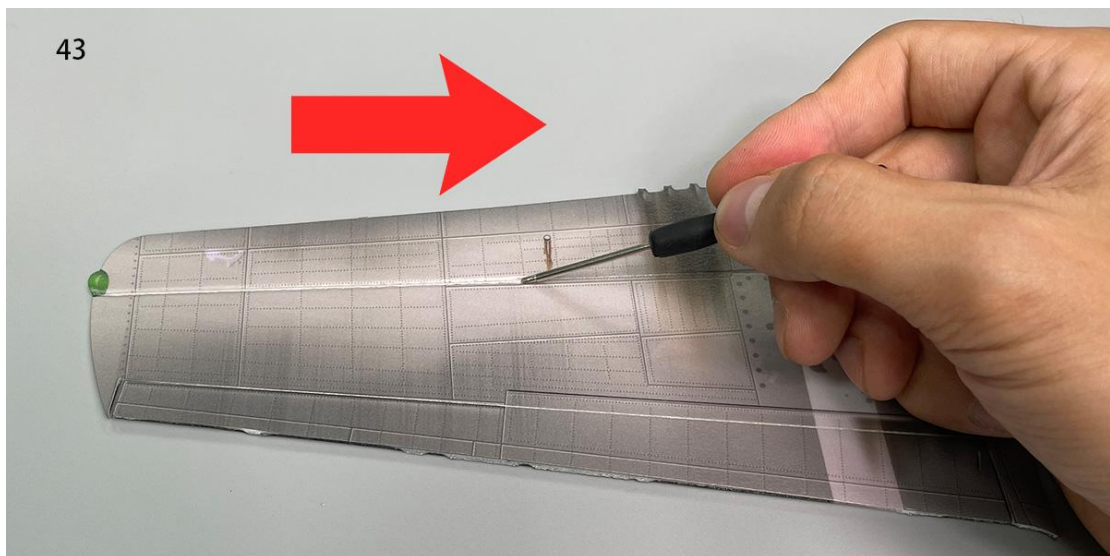

44. Use a sharp tool (screwdriver) to score along the aileron's marked line, allowing the aileron to move up and down along the line.

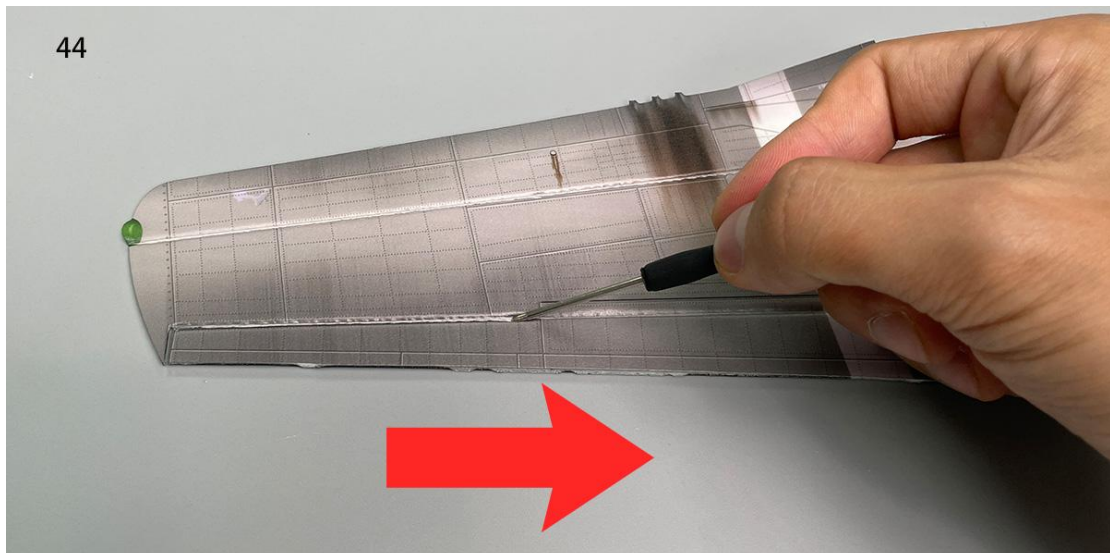



45. Paste carbon fiber rods at the bottom of the wing to increase wing strength.

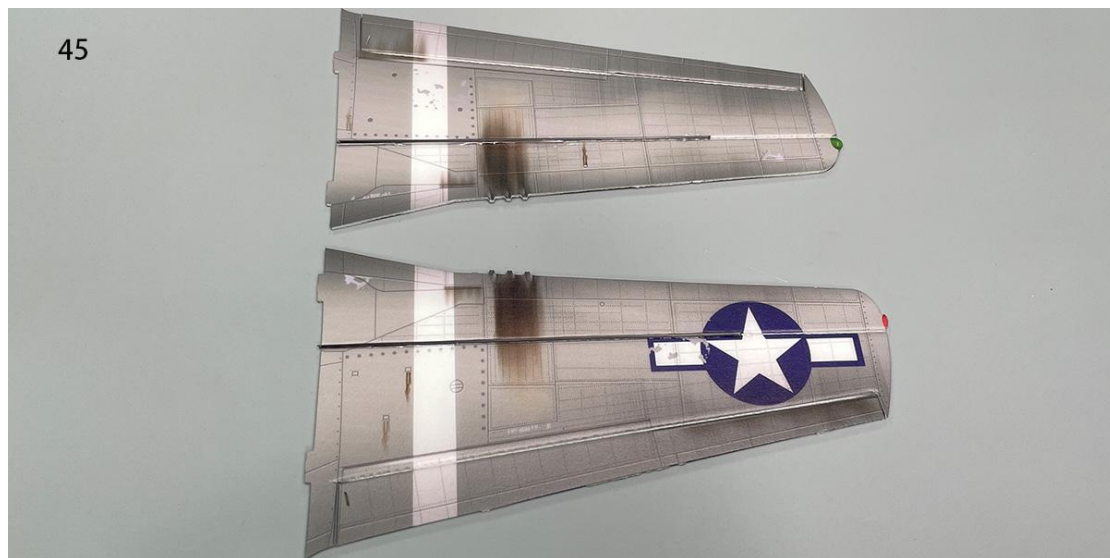

46. Install the wings.



47. Assemble the components required for retracting and extending the landing gear.

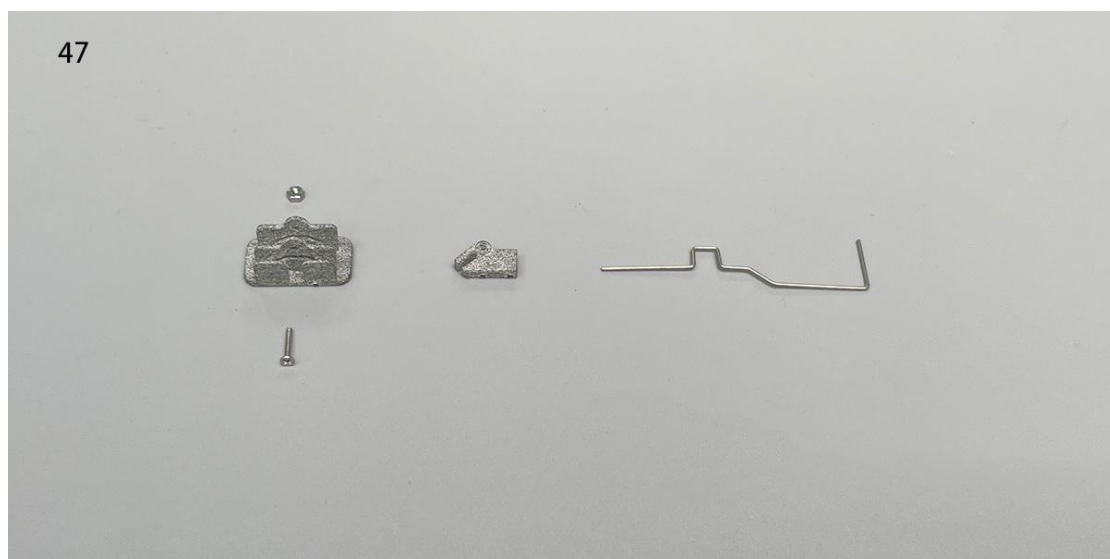

48. Install the landing gear wires into their respective holes and secure them with adhesive (as shown in the diagram).

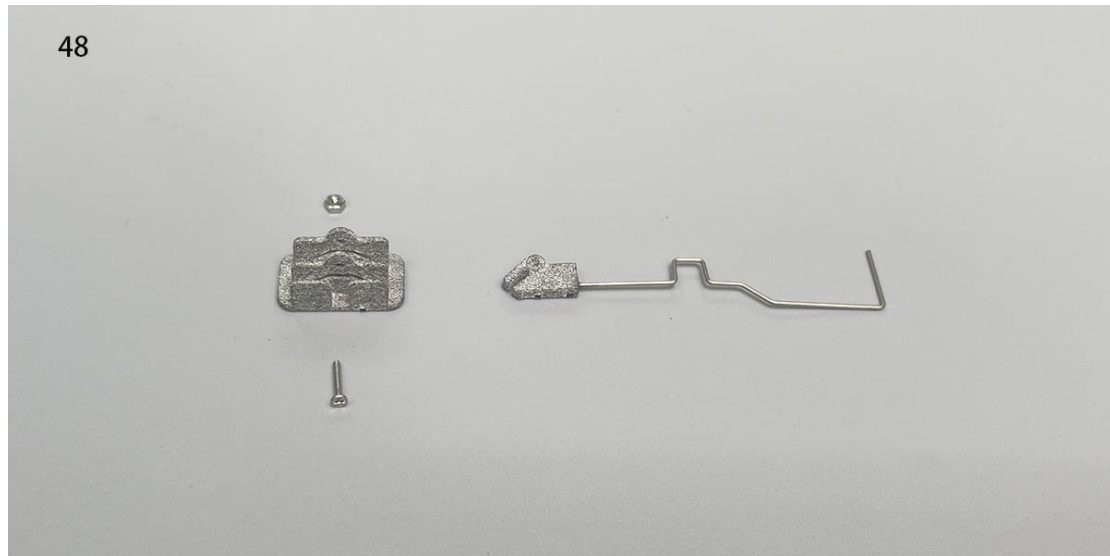

49. Assemble the retracting and extending mechanism using screws and nuts (as shown in the diagram).

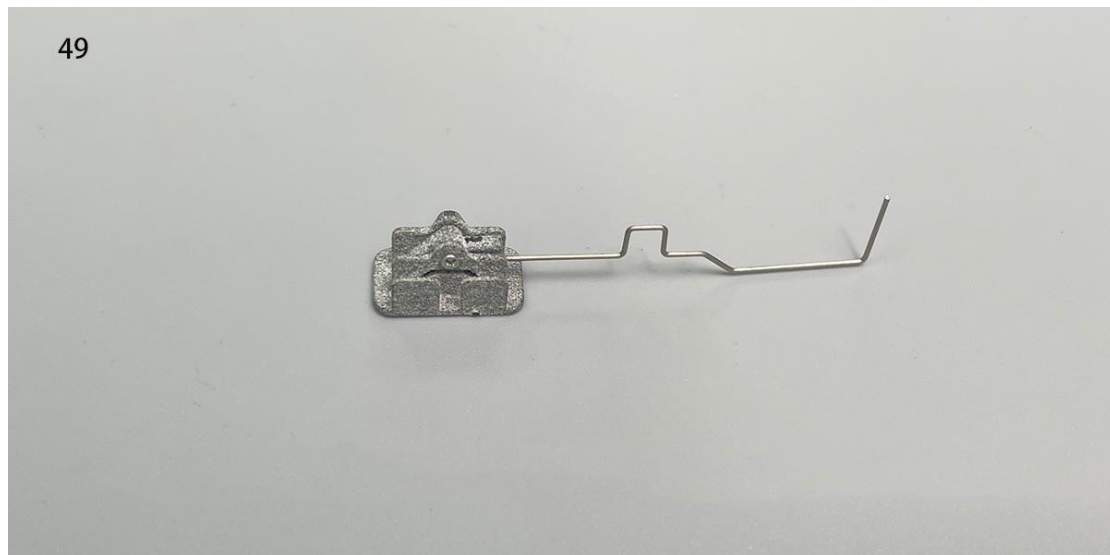

50. Adjust the tightness of the screws and nuts to allow for smooth movement.

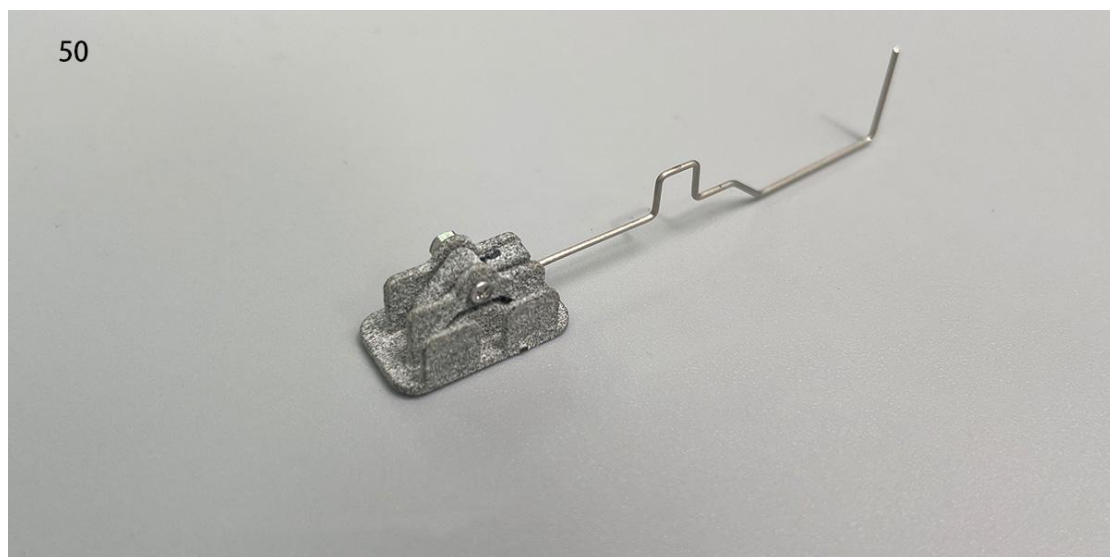

51. Use adhesive to secure the nuts in place to prevent them from coming loose.

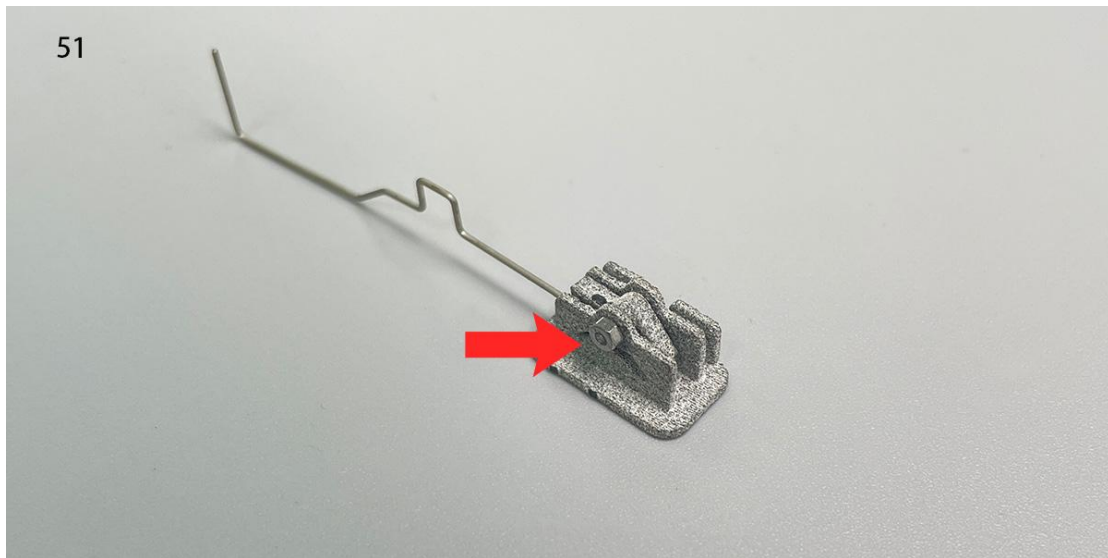

52. The landing gear on both sides is designed with mirror symmetry. Please assemble both sides of the landing gear in a mirrored symmetrical manner to avoid any confusion.

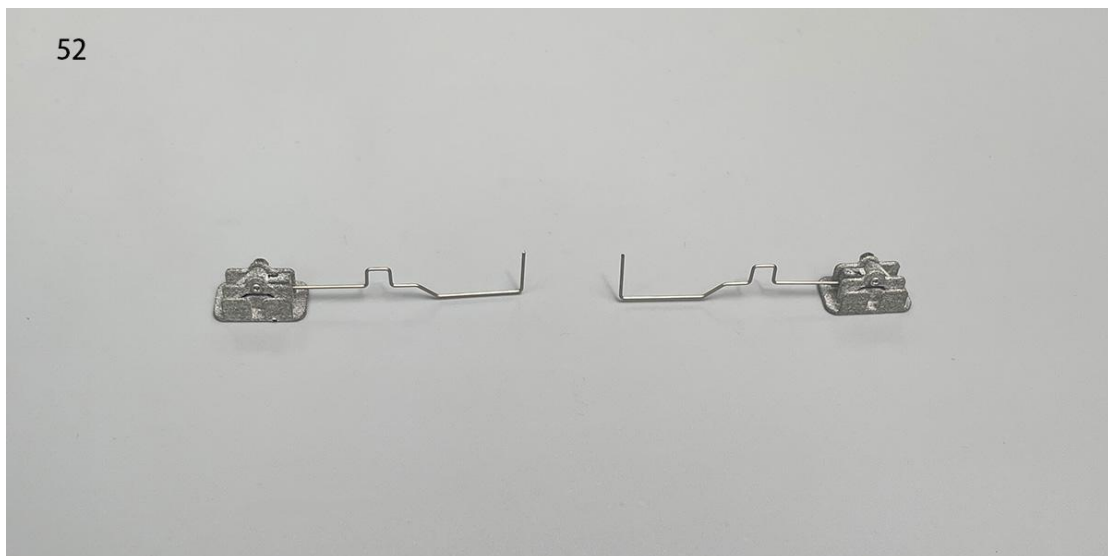

53. Axle sleeves, hubs, and tires.



54. Assemble the axle sleeve and hub, securing with glue.

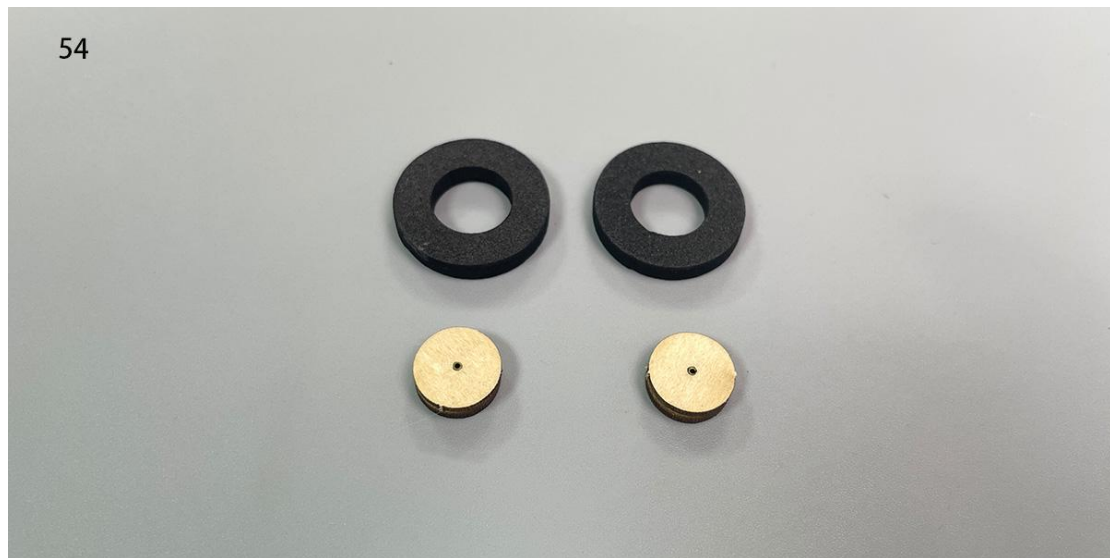

55. Assemble the hub and tire, securing with glue.



56. Apply stickers to the hub.



57. Install the wheels and bend the landing gear wire ends upward to prevent the wheels from coming off. Alternatively, cut a small piece of heat shrink tubing, slide it onto the end of the wire, shrink it, and apply a small amount of adhesive to prevent the wheels from coming off.



58. Use adhesive to secure the landing gear in the corresponding position on the bottom of the wing.



59.

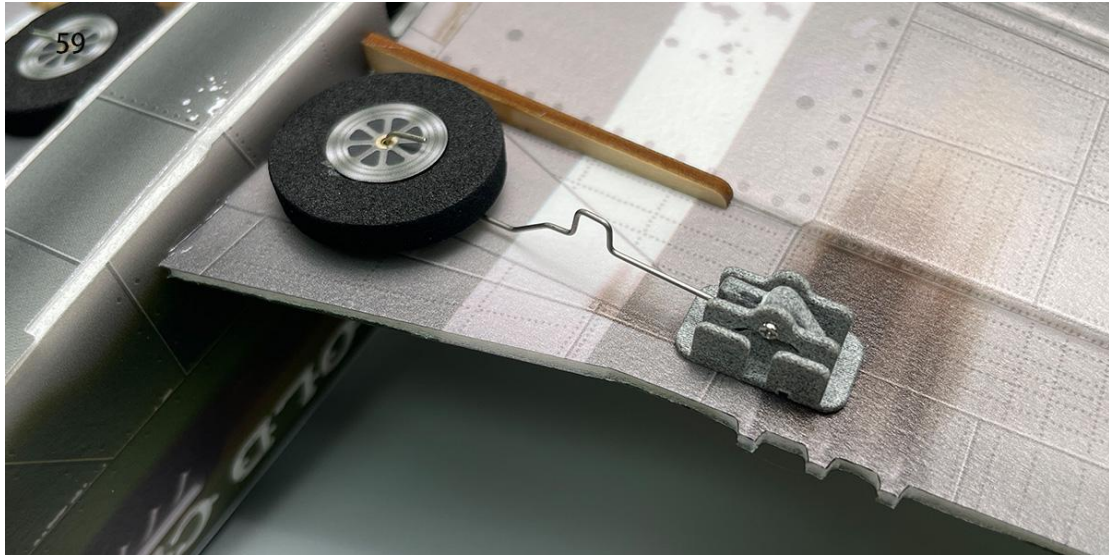

60. Check the operation of the landing gear servo while it is powered on to ensure it functions correctly (as shown in the diagram).

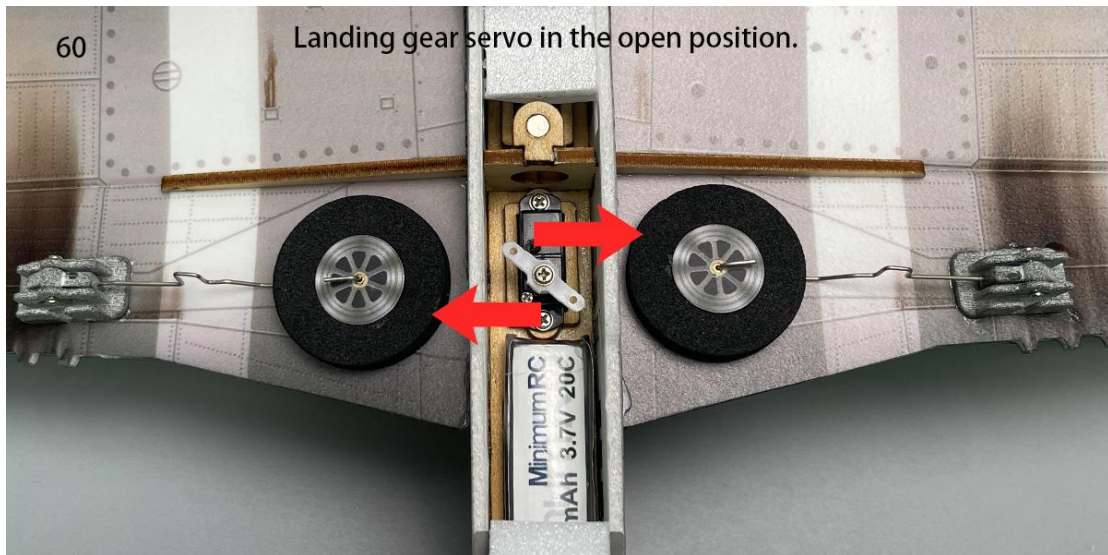

61.

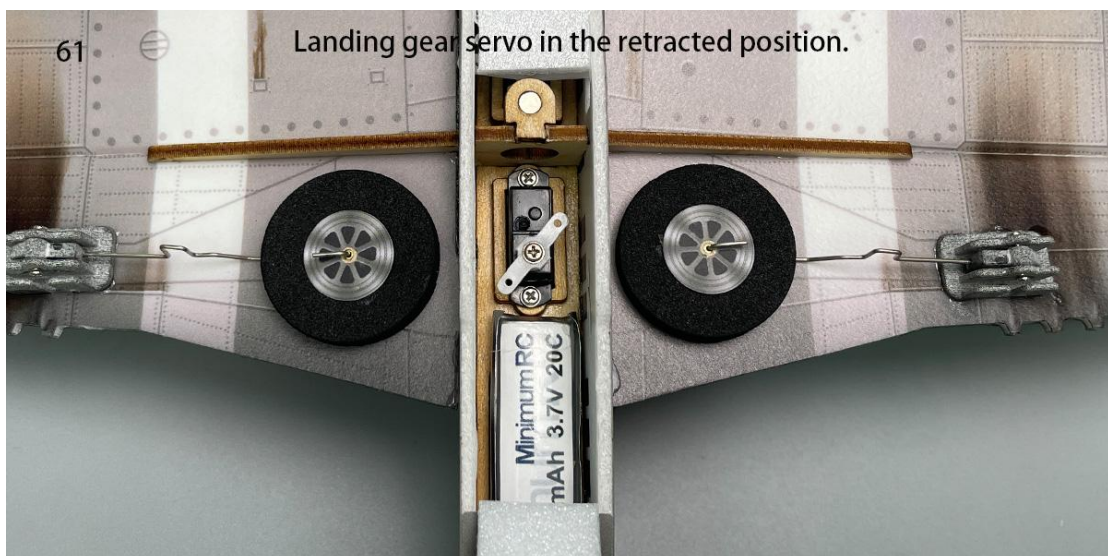

62. Cut the corresponding area on the airframe to the landing gear servo to allow the rod to pass through (as shown in the diagram).



63.

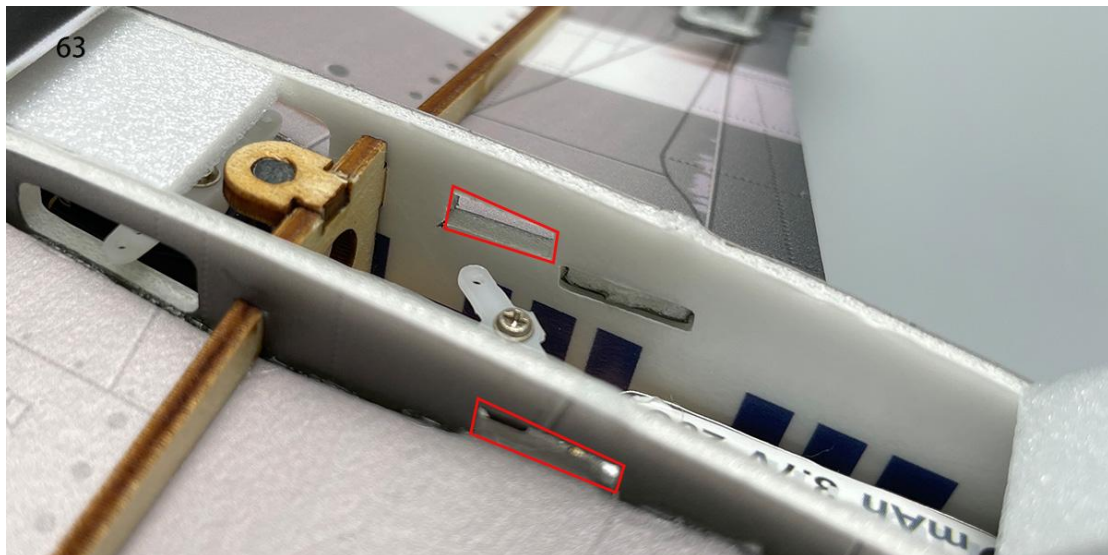

64.



65. Cut two pieces of 15mm carbon rod.

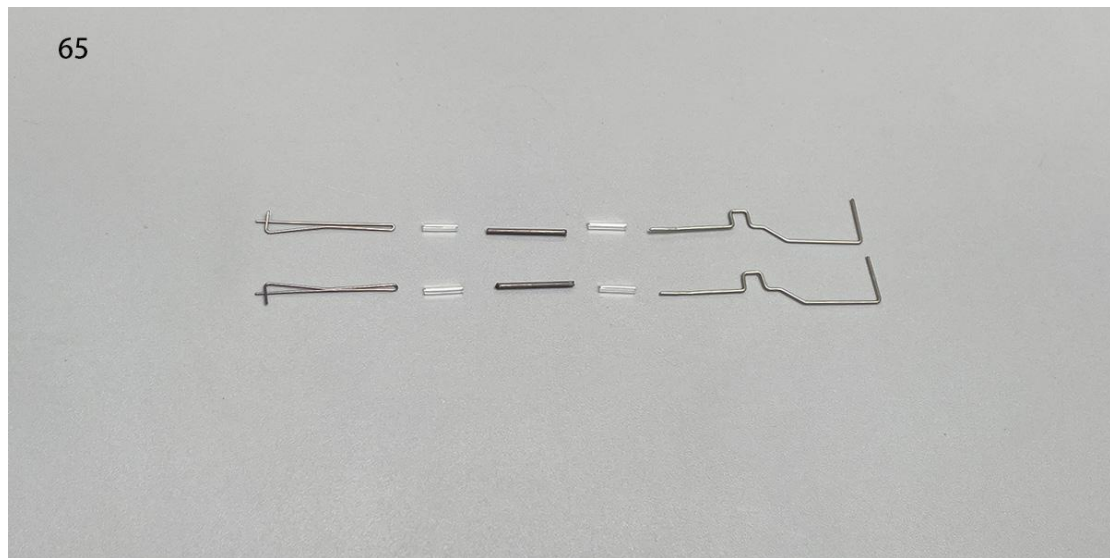

66. Use heat shrink tubing to connect the rod and the servo wire end, and apply a small amount of 502 adhesive to secure it.

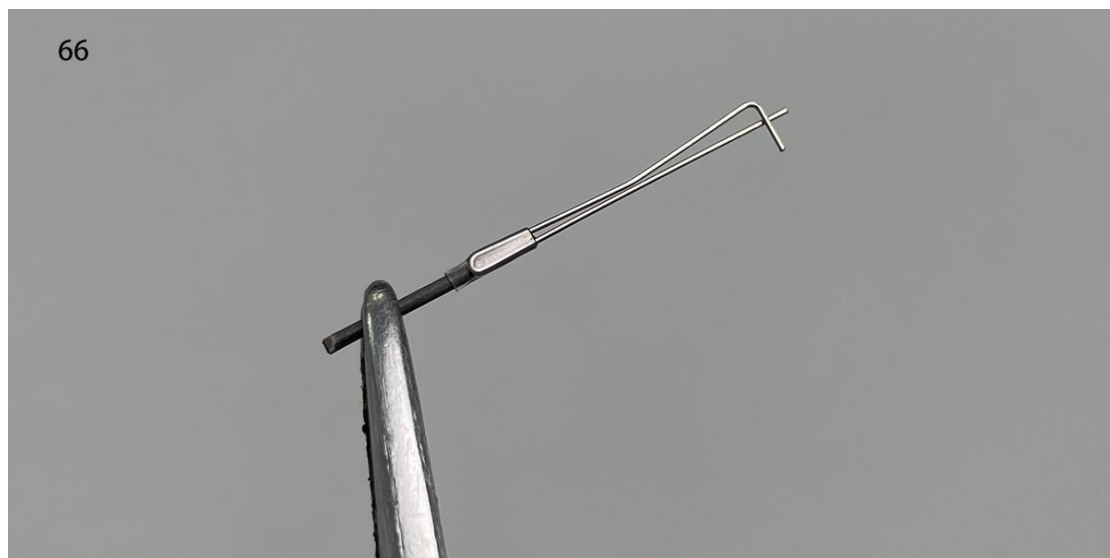

67. Install the rod end clamp onto the servo arm.

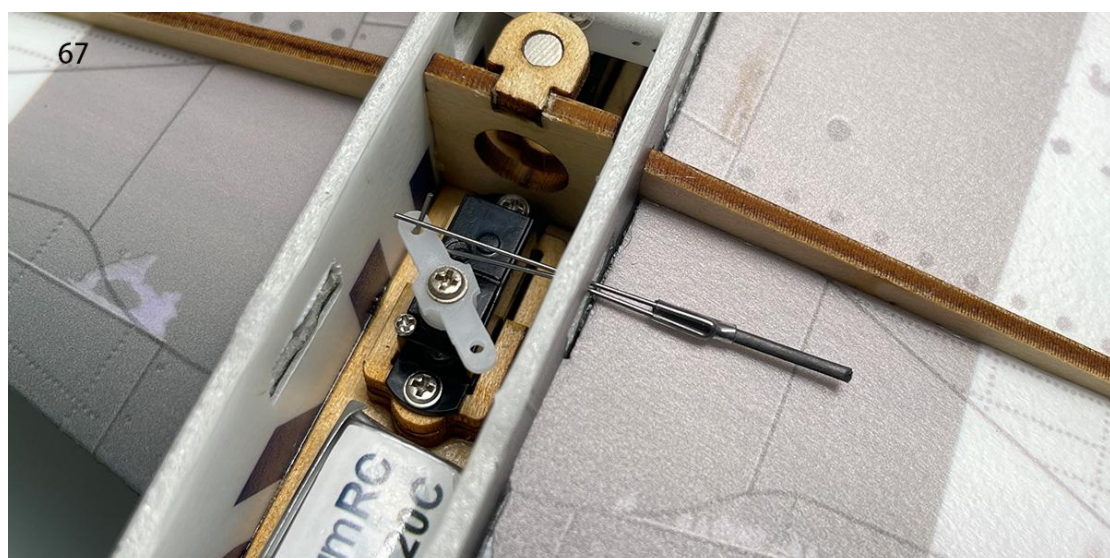



68. Install the landing gear drive rod into the groove.

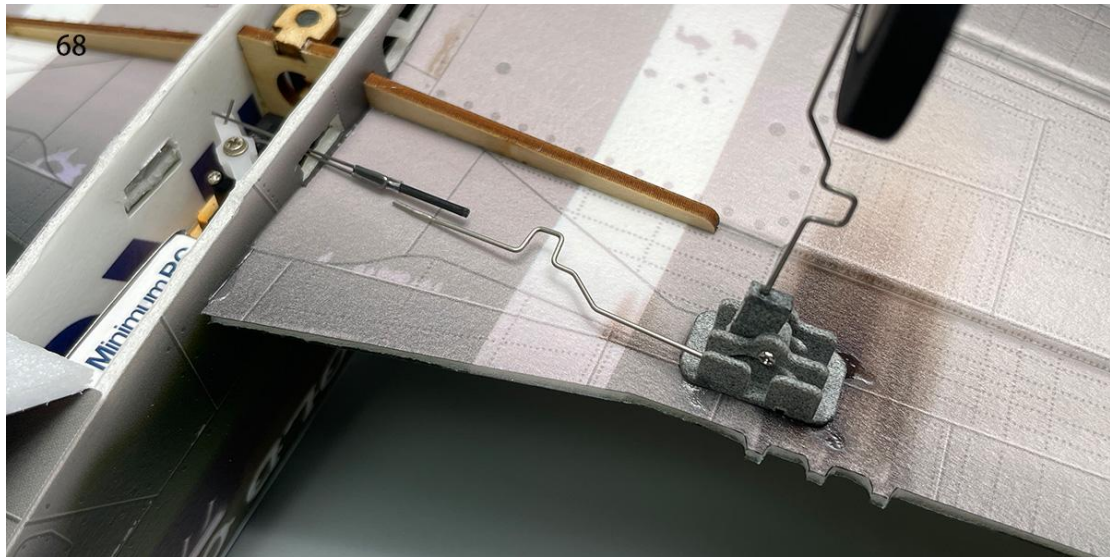

69. Use heat shrink tubing to connect the rod and the drive rod, and apply a small amount of 502 adhesive to secure it.

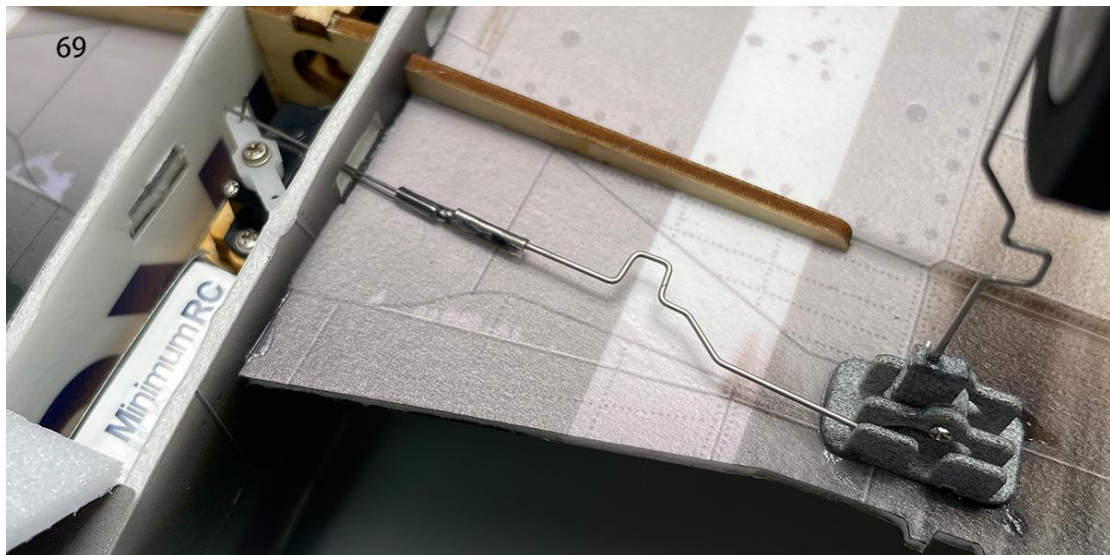

70. Install the other rod on the opposite side in the same manner, making sure the opening of the rod end clamp faces downward.

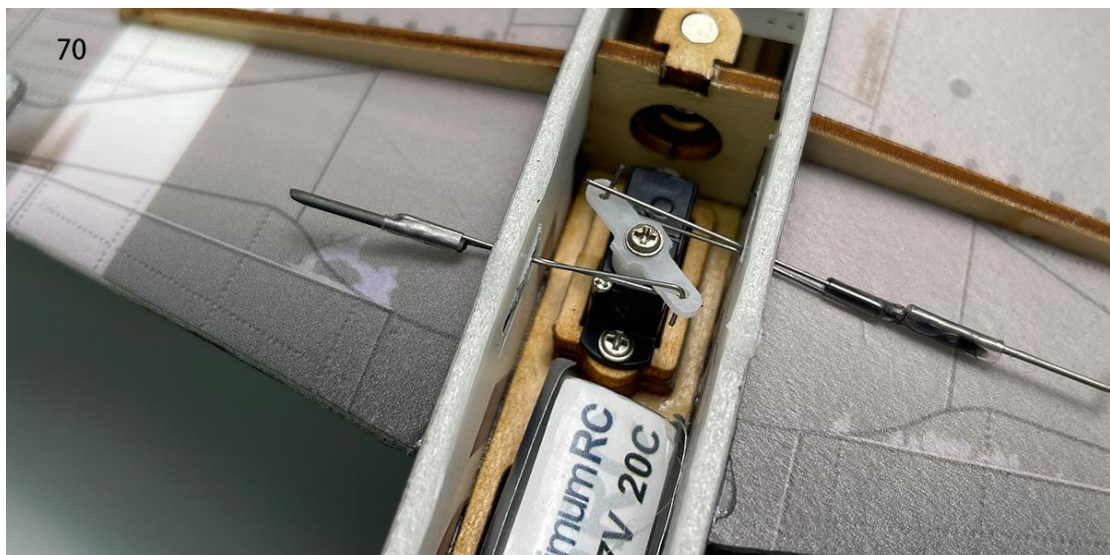

71. Adjust the length of both rods to ensure that the landing gear retracts and extends evenly into the correct position.

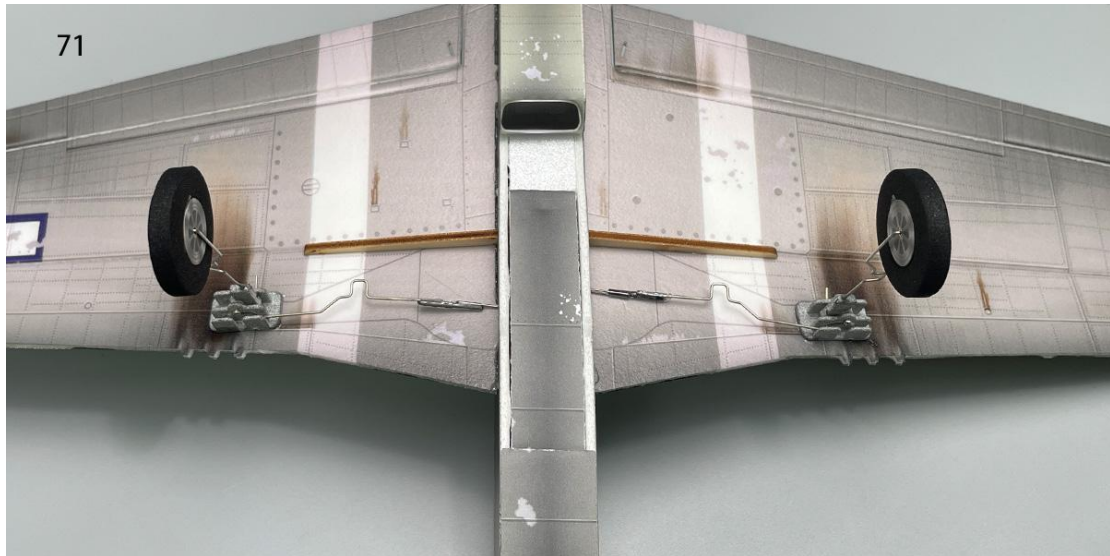

72. Bend the landing gear wires slightly towards the front of the aircraft.



73. Adjust the landing gear wires so that they are vertical to the ground when in the open position.



74. Install the landing gear cover reinforcement.

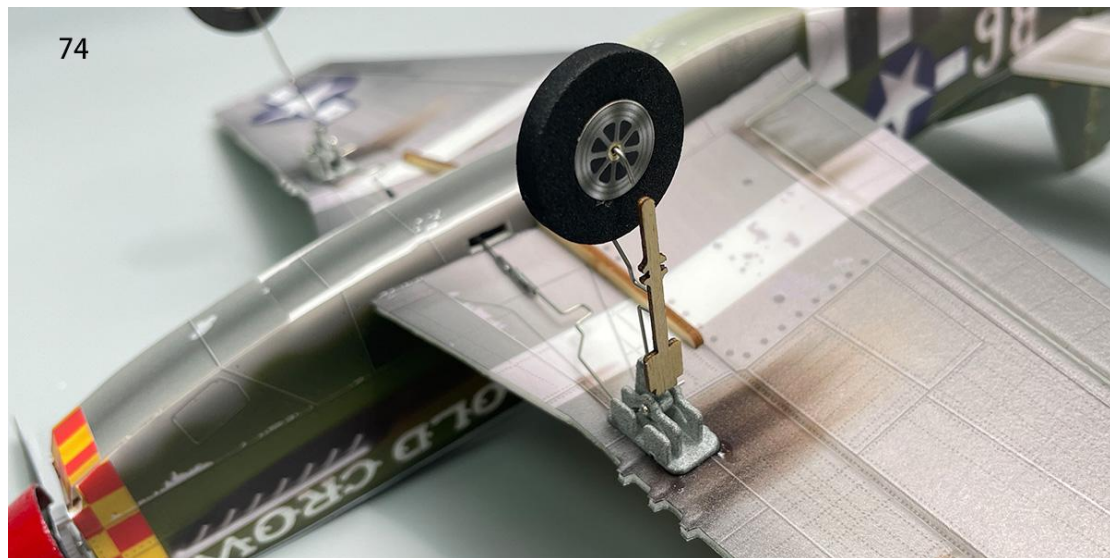

75. Install the landing gear rigid reinforcement structure in the corresponding positions.

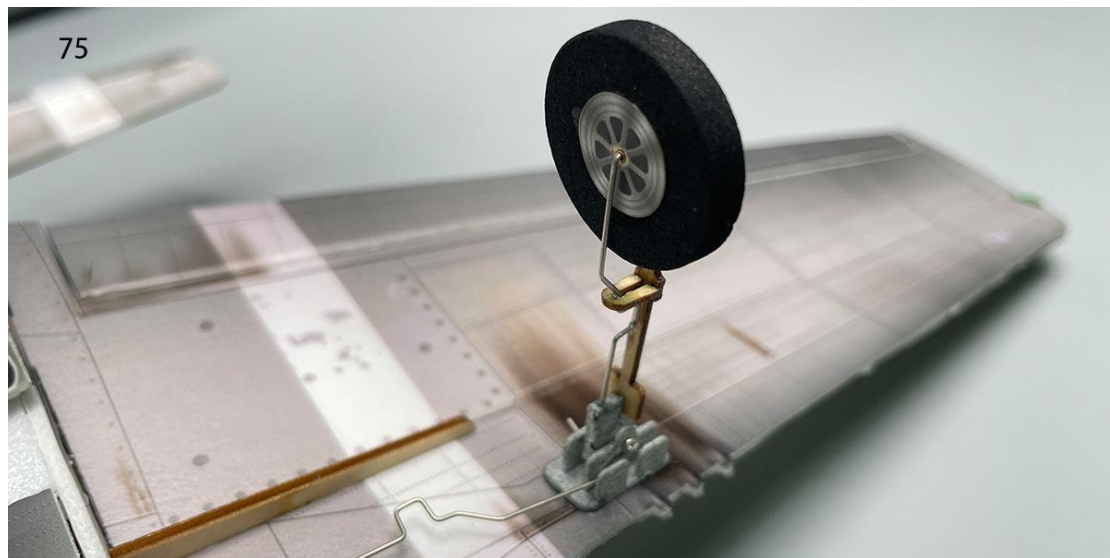

76. Install the landing gear cover plate.

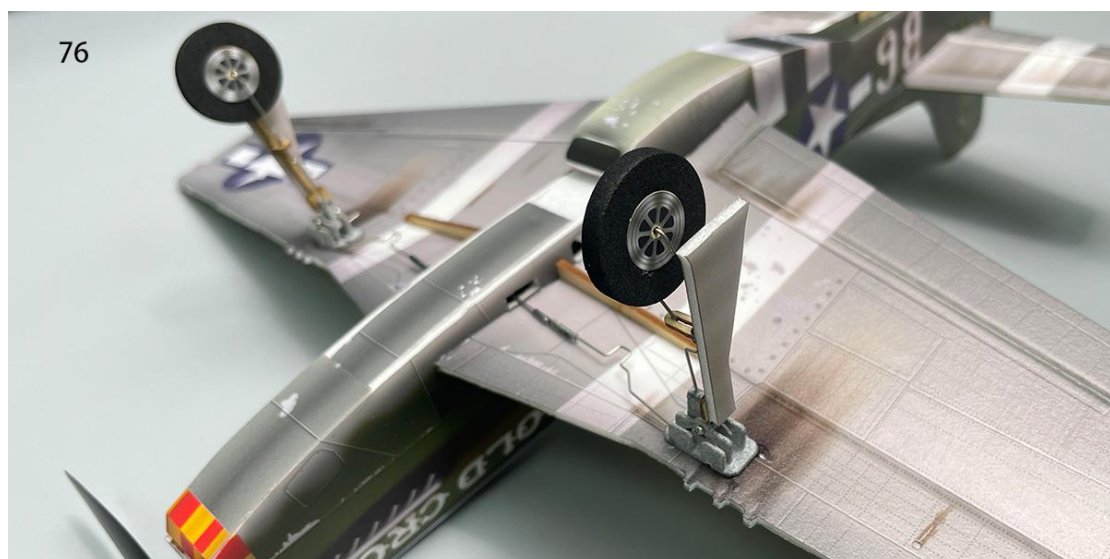

77. Install the aileron control horns.

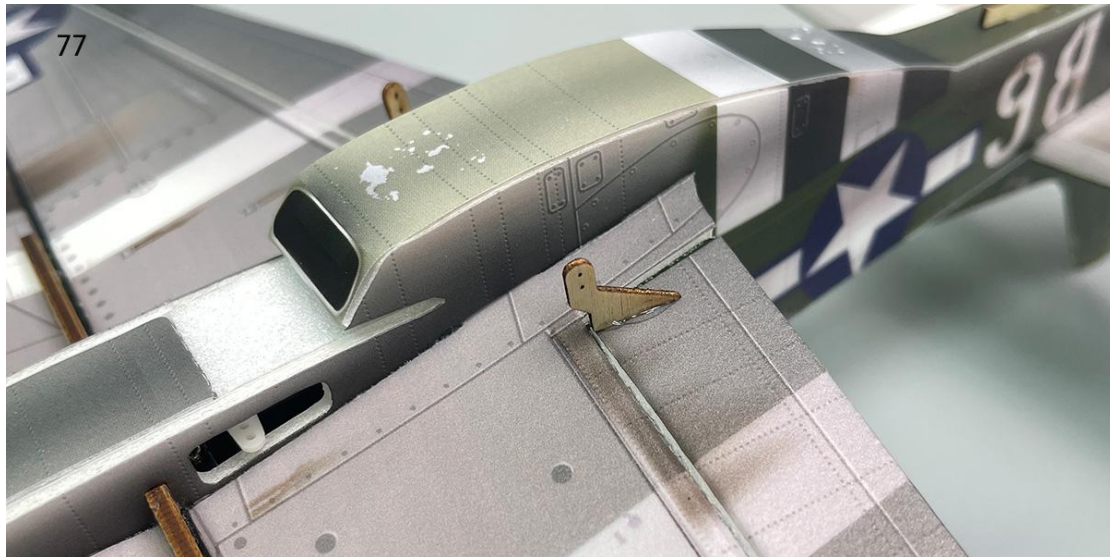

78. Install the horizontal stabilizer control horns.



79. Install the vertical stabilizer control horns.



80. Cut four 5mm lengths of heat shrink tubing for connecting the tail control rods and wire.

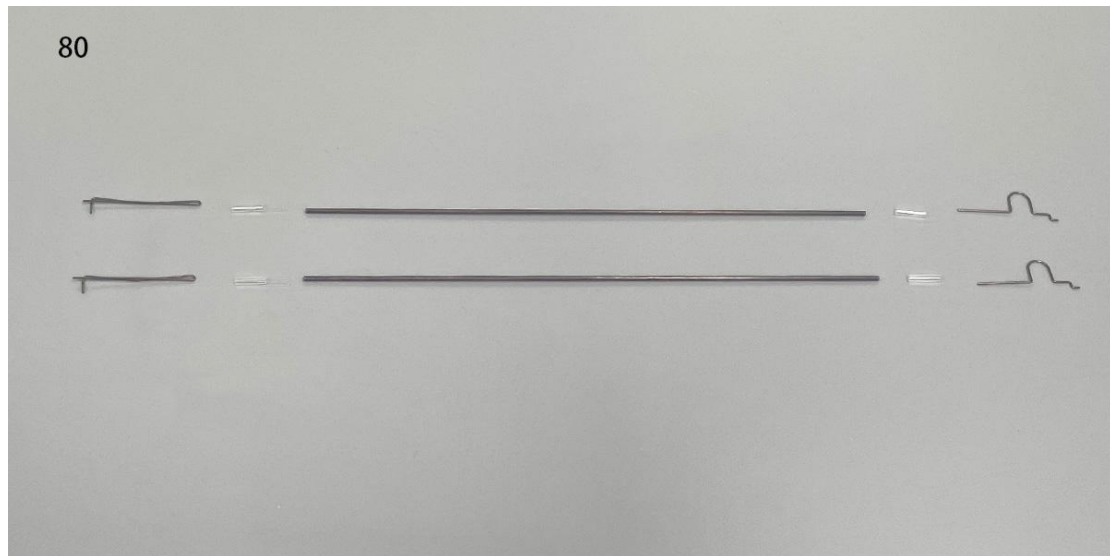

81. Use heat shrink tubing to connect the control rods and servo wire clamp heads, then apply 502 glue for fixation.



82. Install connection hooks on the tail control horns.

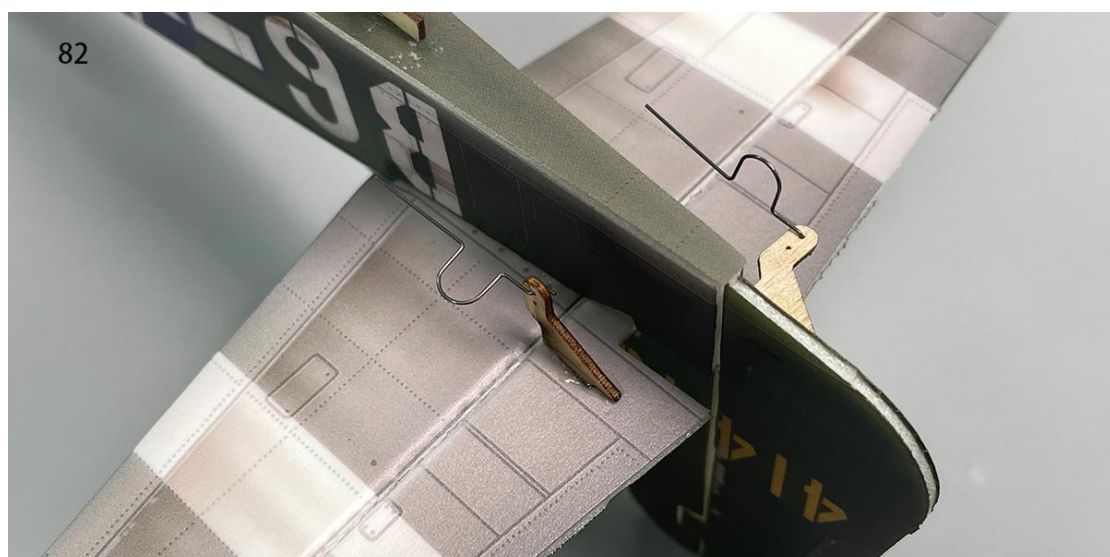

83. Mount the control rod clamp heads on the servo arms.



84. Trim the carbon fiber rod to the appropriate length. Use heat shrink tubing to connect the carbon fiber rod to the connection hook, then apply 502 glue for fixation.

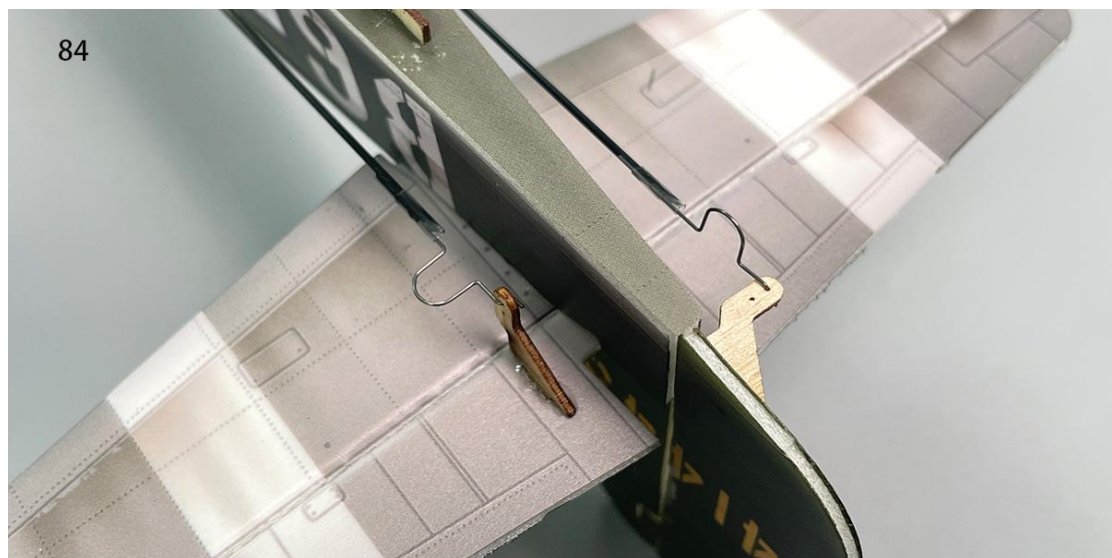

85.

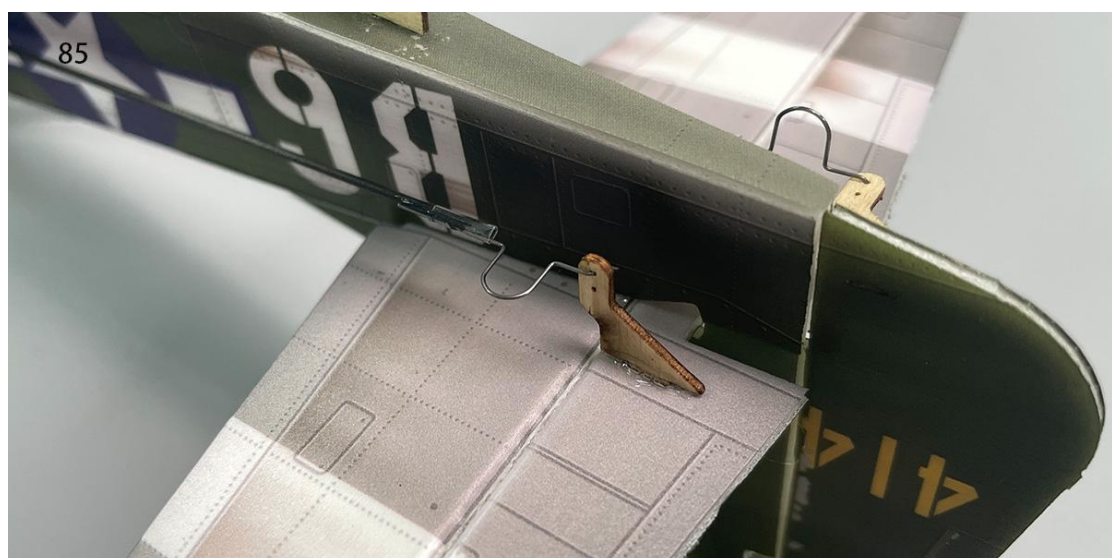

86.

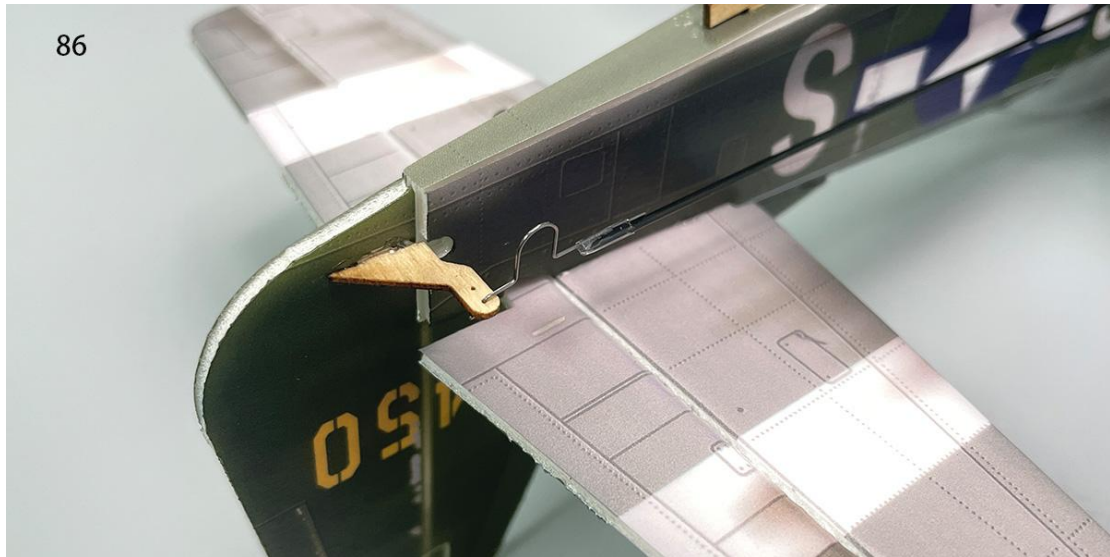

87. Install connection hooks on the aileron control horns.



88. Insert the wire clamp heads into the fuselage and install them on the aileron servo arms.



89. Use heat shrink tubing to connect the aileron wire clamp heads to the connection hooks, then apply 502 glue for fixation.



90. Place the battery in the cabin.



Assembly complete!





## Maiden flight

- The center of gravity of the aircraft is located at the front score line of the wing.
- The active range of ailerons, elevator and rudder is 5mm on both sides.
- choose grass land for maiden flight.
- Under no circumstances should the landing gear in motion be obstructed, as it may result in damage to the servo gears.

**MinimumRC™**

*THE ULTIMATE POSSIBILITIES OF  
RC AVIATION*